

# social swing





# Maciej Karpniak

A Polish designer, a graduate in interior design at the University of Applied Arts in Szczecin. During his studies he was three times awarded the President's scholarships for outstanding artistic talent.

The author of Social Swing, Booi and Alberi. Maciej works at the Academy of Art in Szczecin, where he runs the Bionics and Multidisciplinary Product Design workshop.

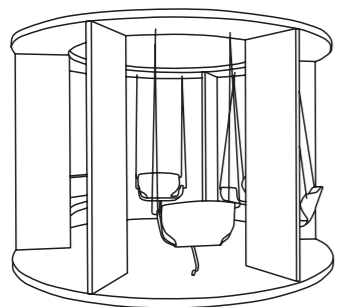

Social Swing

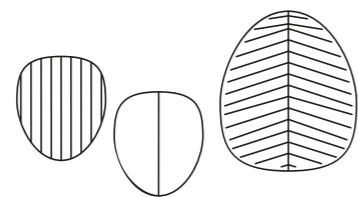

Alberi



Booi

## social swing **philosophy**

Daily work is a constant challenge, meetings in a rush, dozens of issues to discuss, responsible decisions to make. Move your team from the conference room to a less standard meeting place like Social Swing and see how creativity of your employees is revived and teamwork improves.

Create with us a space where everyone feels safe and equal with others. Social Swing subconsciously increases creativity and makes everyone share their own, even the most unusual, ideas. Bring some movement to your daily meetings and enjoy the benefits of swinging.





# social swing

## round

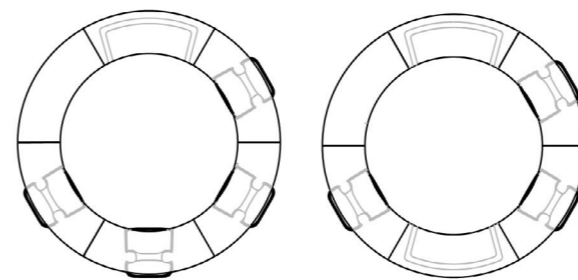

Depending on the configuration, the furniture set can be used by 1 to 10 people at the same time. An example of arrangement for minimum 6 people includes four suspended armchairs and one double sofa. The maximum number of people is 10 with a system of five double sofas. One place must always remain free, allowing free passage. A single suspended armchair cannot be used by more than one person.

The recommended distance from the passageways should not be less than 80 cm from the maximum point of inclination of the armchair.



# social swing

## double

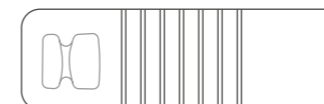

The semi-open form of a double swing invites you inside, creating a properly soundproofed space. The furniture is supplemented with a table and can be used as a temporary place of work or rest.

Depending on the configuration, the furniture set can be used by 1 to 2 people at the same time. A single suspended armchair cannot be used by more than one person.

The recommended distance from the passageways should not be less than 80 cm from the maximum point of inclination of the armchair.



# social swing

single



Social Swing single helps you gather thoughts, relax and calm down. It is an ideal product that will regenerate your mind during a short break.

A suspended armchair cannot be used by more than one person.

The recommended distance from the passageways should not be less than 80 cm from the maximum point of inclination of the armchair.



# let's swing

Social Swing creates an informal meeting place that stimulates creativity, and at the same time brings the atmosphere of a park to the office space. It is here, in the atmosphere of free discussion, that the most inspiring ideas and surprising ideas can arise.

Light swinging perfectly calms emotions, stimulates concentration and promotes efficiency. The suspended seats promote movement and perception, spatial awareness, general fitness, social interaction and sensory integration, including the development of coordination and balance. Check for yourself how Social Swing will change your team.

## Did you know that Social Swing...

1. supports the production of endorphins
2. helps you create new neural connections
3. develops better orientation in space
4. relaxes
5. soothes the deep feeling
6. stimulates creativity
7. is developed according to the idea of biophilic design
8. supports team building
9. can be a source of inspiration





# what makes social swing different?

## office product

Social Swing is a furniture set with suspended armchairs used inside buildings, and in office and public spaces.

## technical tests

The product has been tested for strength and durability, structural stresses, loads, stability and safety.

## safety

The furniture set does not need to be mounted to the floor. Each armchair is equipped with a nylon strap that limits the inclination of the armchair and increases the safety of its users and passers-by.



## sociofugal space

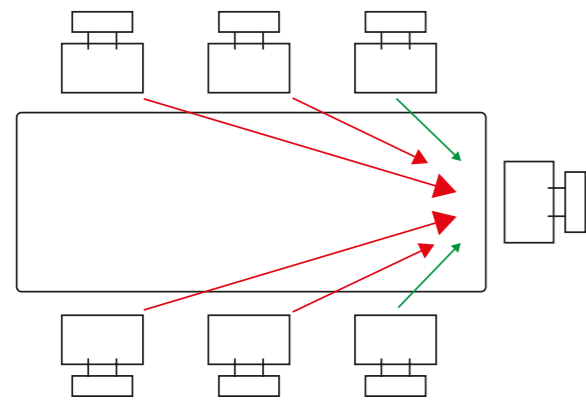

## sociopetal space

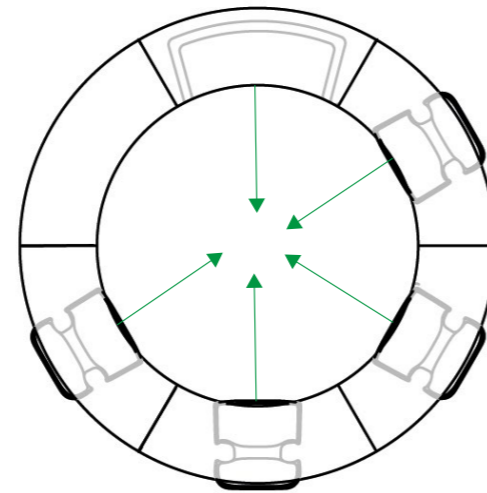

Spaces can be designed in a sociopetal or sociofugal way, that is in a way which promotes or discourages human interactions.

Social Swing is a perfect example of office furniture that supports communication and reduces the distance between people. The sociopetal space cannot be overloaded by visual or auditory stimuli, hence the acoustic properties of social swing additionally improve communication. In Social Swing everyone is equal, hence it is so easy to open up to the ideas of yourself and another person.

Social Swing also realizes the assumptions of Goffman's theory – the office is a place where we can separate the stage and backstage – informal, casual conversations are held in the backstage.



# biophilic design

The Bejot products are the answer to an ever louder and more dynamic life. By supporting the biophilic objectives, we want to help, even the most busy ones, rebuild contact with nature and build a dynamic landscape of office and public spaces.

We are aware that offices can be loud and make you nervous. All the sounds around us can cause a loss of concentration, headaches and even irritation. However, you can overcome this by taking care of acoustics in the rooms you stay in.

Social Swing is a product that fits into the idea of biophilic design and ensures proper room acoustics.

## tests show

that elements of nature in the office and good acoustics have a huge impact on employees\*:

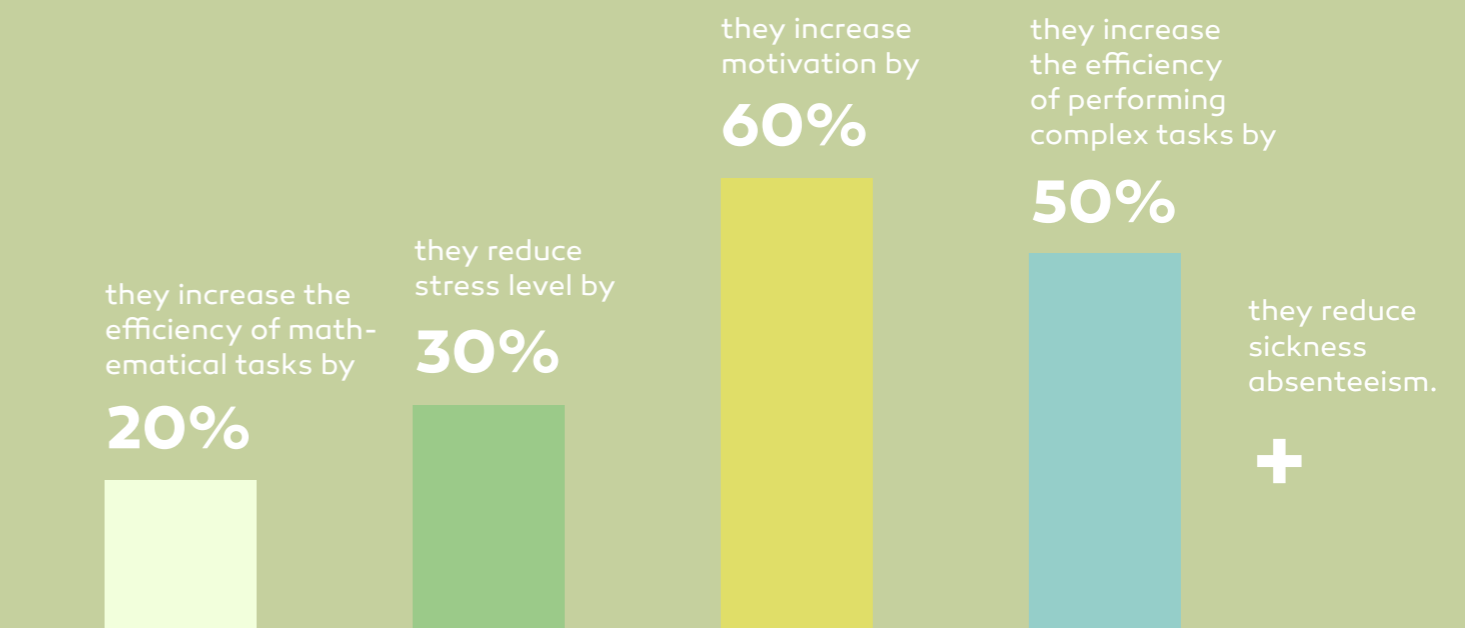

\* C. Cooper, Human Spaces Report: Biophilic Design in the workplace



# social swing

was developed according to the idea of biophilic design

## eco-safe fabrics

The range of products includes recycled fabrics, woollen fabrics and recyclable fabrics. All fabrics are available in a wide range of colours.

## wooden components



## colours inspired by nature

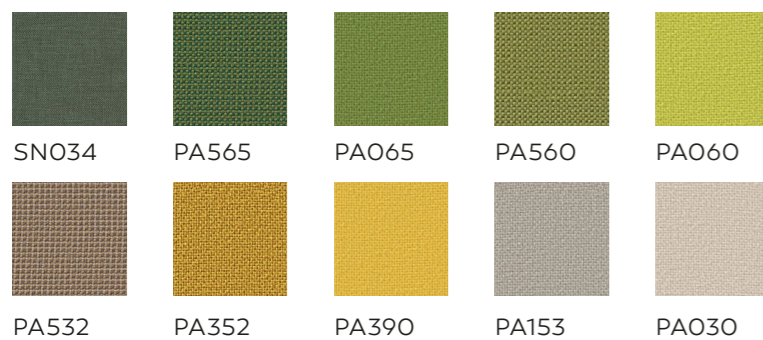

# acoustics

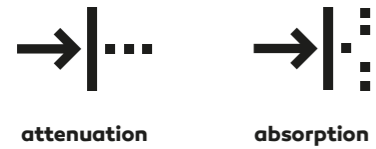

The high and wide walls provide effective sound screening – acoustic waves penetrate into other areas of the office to a less extent and the range of talks is reduced. This allows for effective relaxation during breaks or comfortable conducting meetings in an informal atmosphere, during which the creativity of your team is not disturbed by noise. The structure is covered with a special sound absorbing foam which effectively reduces the noise level in the office and reduces reverberation time. Thanks to its large surface, the sound absorbing material used in Social Swing can effectively replace several wall panels.

estimated sound absorption  $A_{vol} [m^2]$   
in relation to frequency [Hz]\*

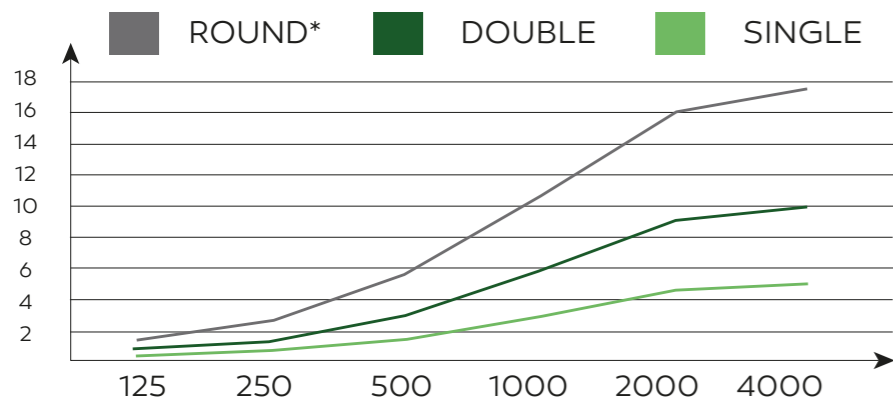

\* results for a system of 4 swinging armchairs with 1 sofa

## wall section



A: fabric  
B: absorbent material  
C: support structure

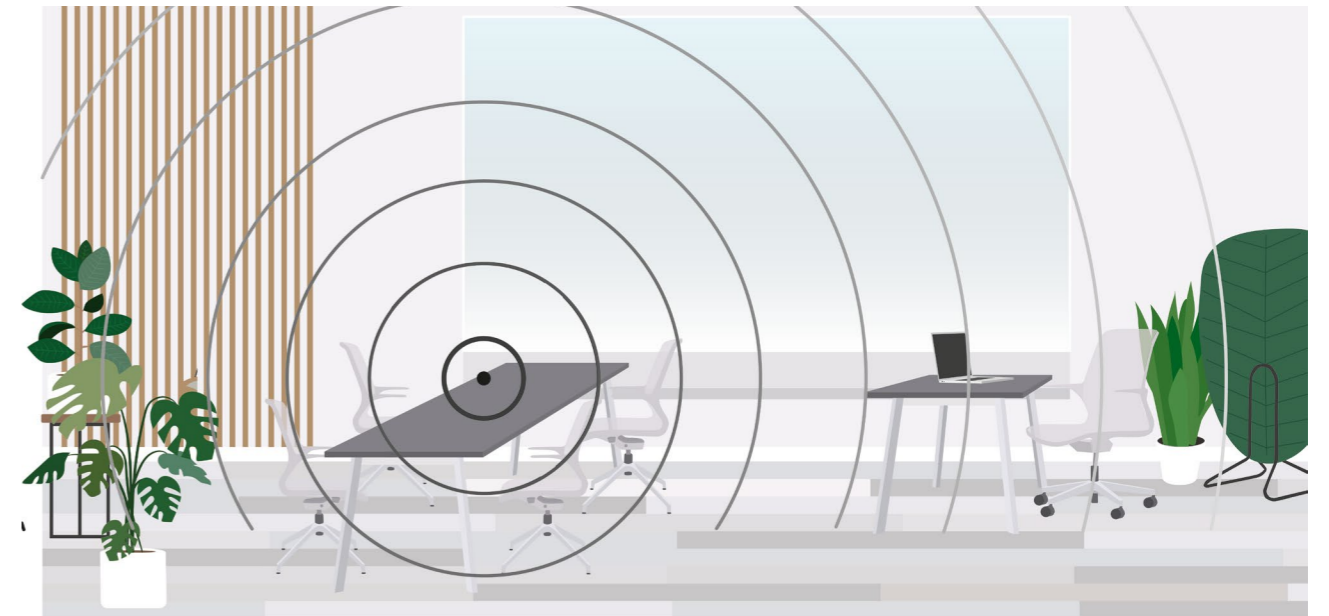

A meeting place in the office space without acoustic solutions. Acoustic waves propagate without any obstacles, there is noise in the office, conversations can be heard even at a long distance – this affects the concentration of office users.

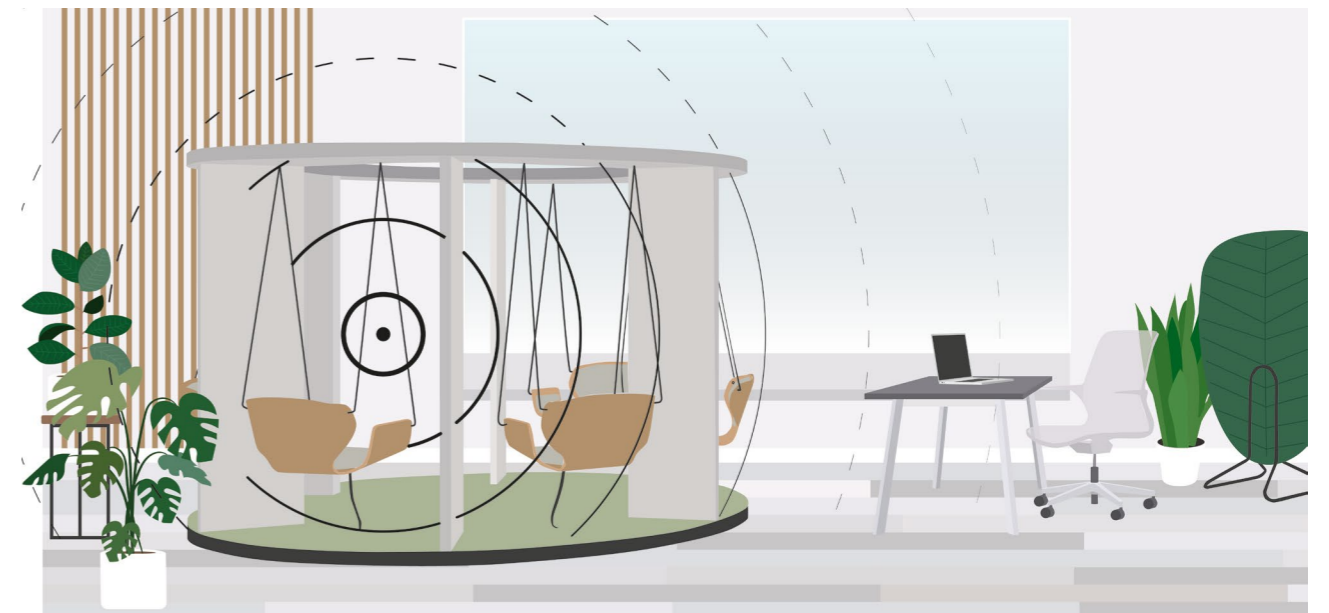

A meeting place in the office space, using Social Swing. The structure of the walls and the roof is an obstacle to the propagation of acoustic waves – it effectively reduces the noise level and limits the range of conversations, providing greater comfort of meetings and relaxation.

# opinions of experts

” Social Swing is a product that meets the necessary standards related to the structure and use of the product. It has undergone a number of tests, including those related to the strength of the furniture and suspended seats structure.

The elements of the structure are made of appropriate materials certified and approved for marketing in the construction industry according to building law. The structure of the armchairs meets the requirements of standards for chairs, which makes the sitting and use comfortable.

In addition, each suspended armchair has a seat tilt lock, i.e. a special nylon belt that prevents excessive inclination outside Social Swing, thus reducing the likelihood of collision with a person standing or walking near a Social Swing product, as well as between its users.

The provided certificates and solutions comply with all occupational health and safety standards and certify that this product can be safely used in public spaces.

”  
**Marcin Jarzyna**  
Chief Health and Safety Officer

” The Social Swing Round furniture set with suspended armchairs complies with the most important requirements for office space designs from the perspective of current sociological knowledge about collective work.

The requirement for an effective meeting is to enable a visual and audible interaction to an optimal extent. The mutual interaction of interlocutors is ensured by the arrangement of seats in a circle. The Social Swing Round design helps create a narrative of common benefits. Interlocutors can see one another in full size, which is not possible at conference tables. This signals greater openness and mutual acceptance. The pendulum movements of bodies on suspended seats act as illustrative gestures and express readiness to speak freely, allowing interlocutors to move away from the main thread of conversation and the method of distant associations. As a result, interlocutors are more willing to use such creative thinking techniques as read-across.

The analysis of the communication situation allows us to conclude that the Social Swing Round furniture set has an impact on the smoothness of creative conversation and its democratic character. Indirectly, it makes the creative process flexible, which should be understood as the willingness of interlocutors to spontaneously change their ways of thinking. It is used to evaluate initial ideas, freely recall and reject various evaluation categories.

”  
**dr Marek Chojnacki**  
university lecturer, researcher of creative processes,  
social communication specialist



# technical data

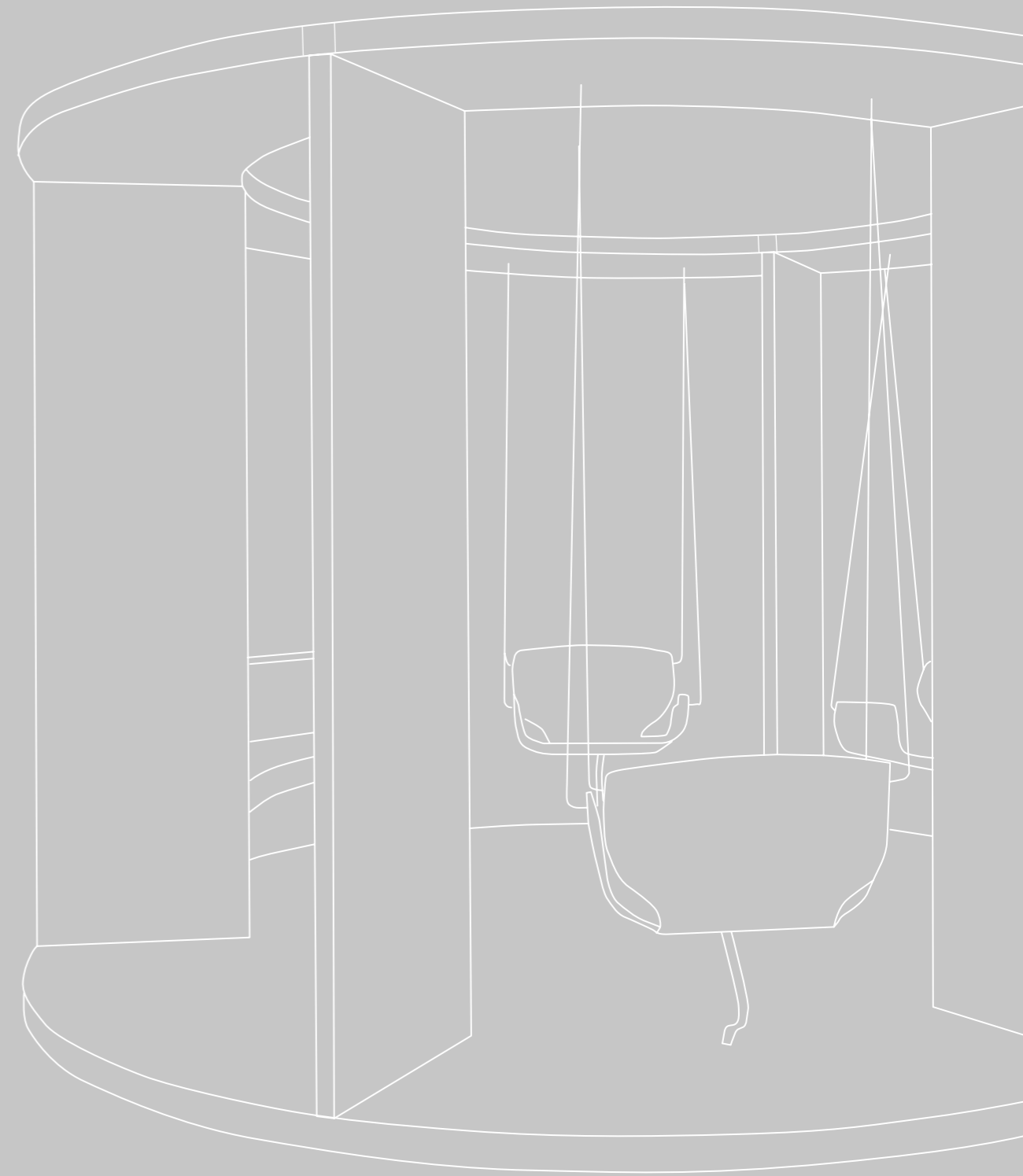



# social swing round

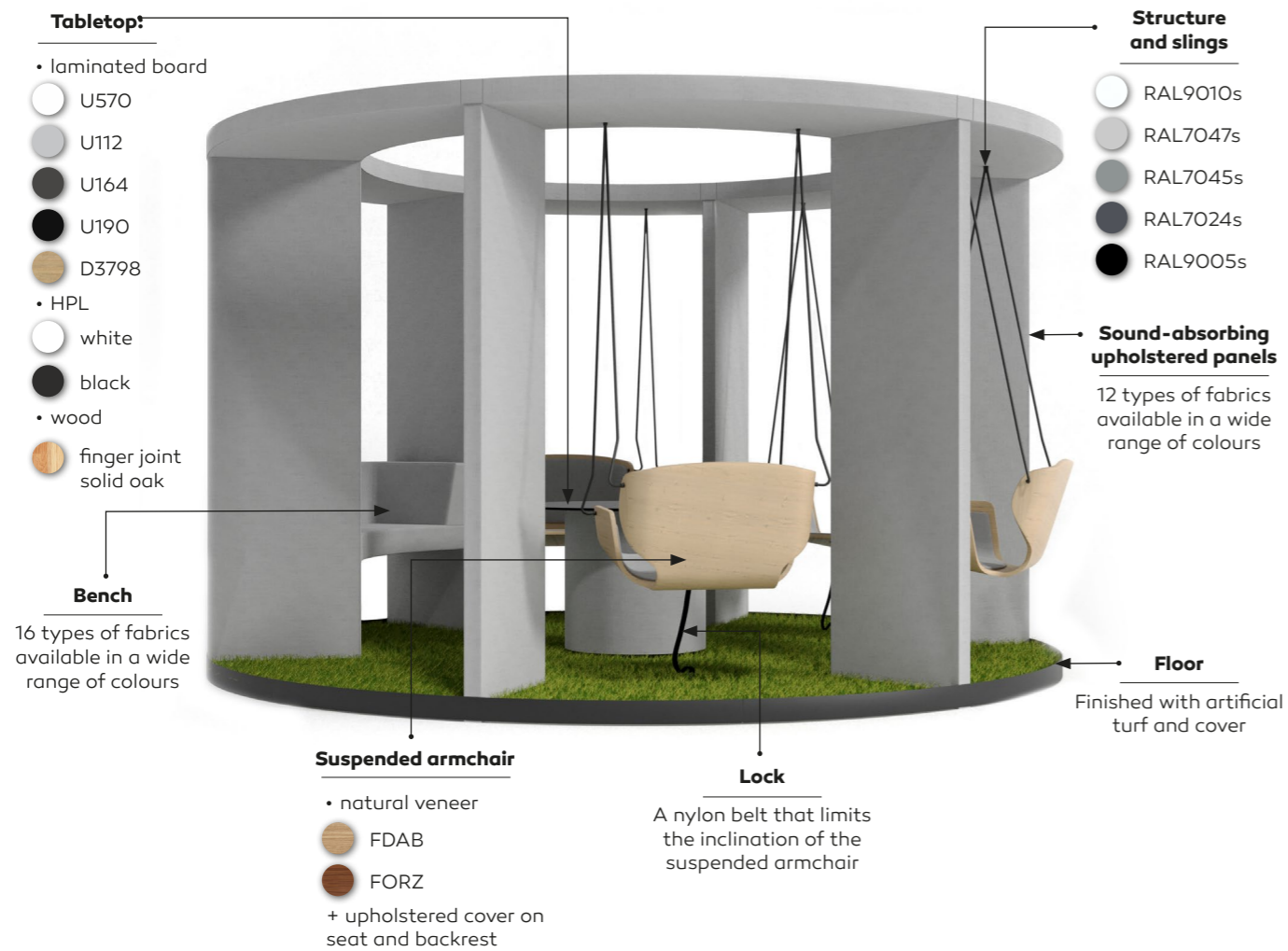

SUSPENDED ARMCHAIR



BENCH



TABLE

## STRUCTURE

Metal structure, powder coated (structure) filled with HDF board, covered with foam and upholstered with fabric.

## SUSPENDED ARMCHAIR

Bucket made of coloured plywood. The cover on the seat and backrest is made of foam upholstered with fabric or leather. The armchair is secured with a nylon strap, attached to the floor, which limits tilt. The seat is hung on metal slings, powder coated, in the colour of the structure. Maximum load of one seat is 150 kg.

## BENCH

Two-person bench made on the basis of a box structure, covered with foam and upholstered with fabric.

## TABLE

Upholstered construction with a 1000 mm diameter top.

## CEILING

The wooden structure placed on a metal frame, covered with foam, upholstered with fabric from the bottom, from the top with a standard wigofil (fabric for an extra charge).

## FLOOR

Wooden structure placed on a steel frame, finished with a cover in the colour of the structure, and artificial grass.

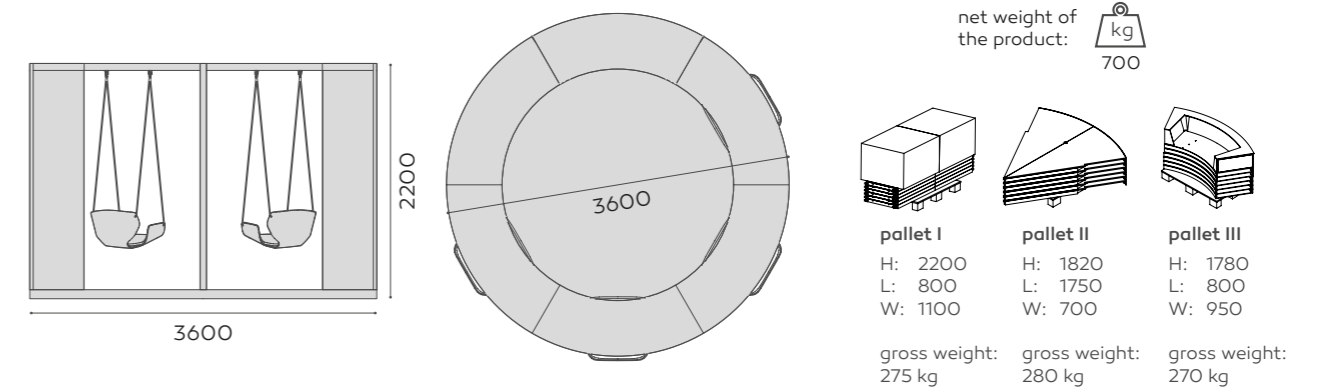
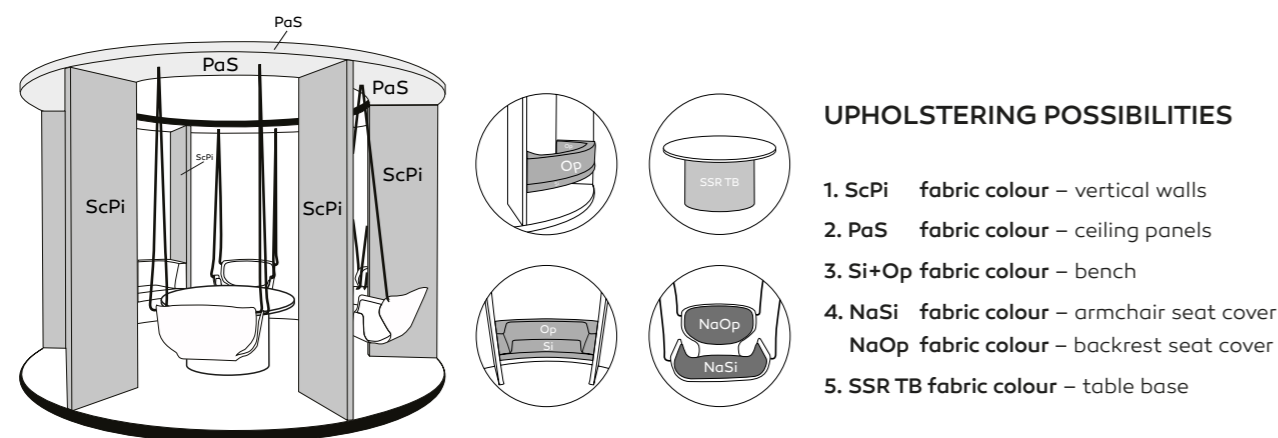

# social swing double

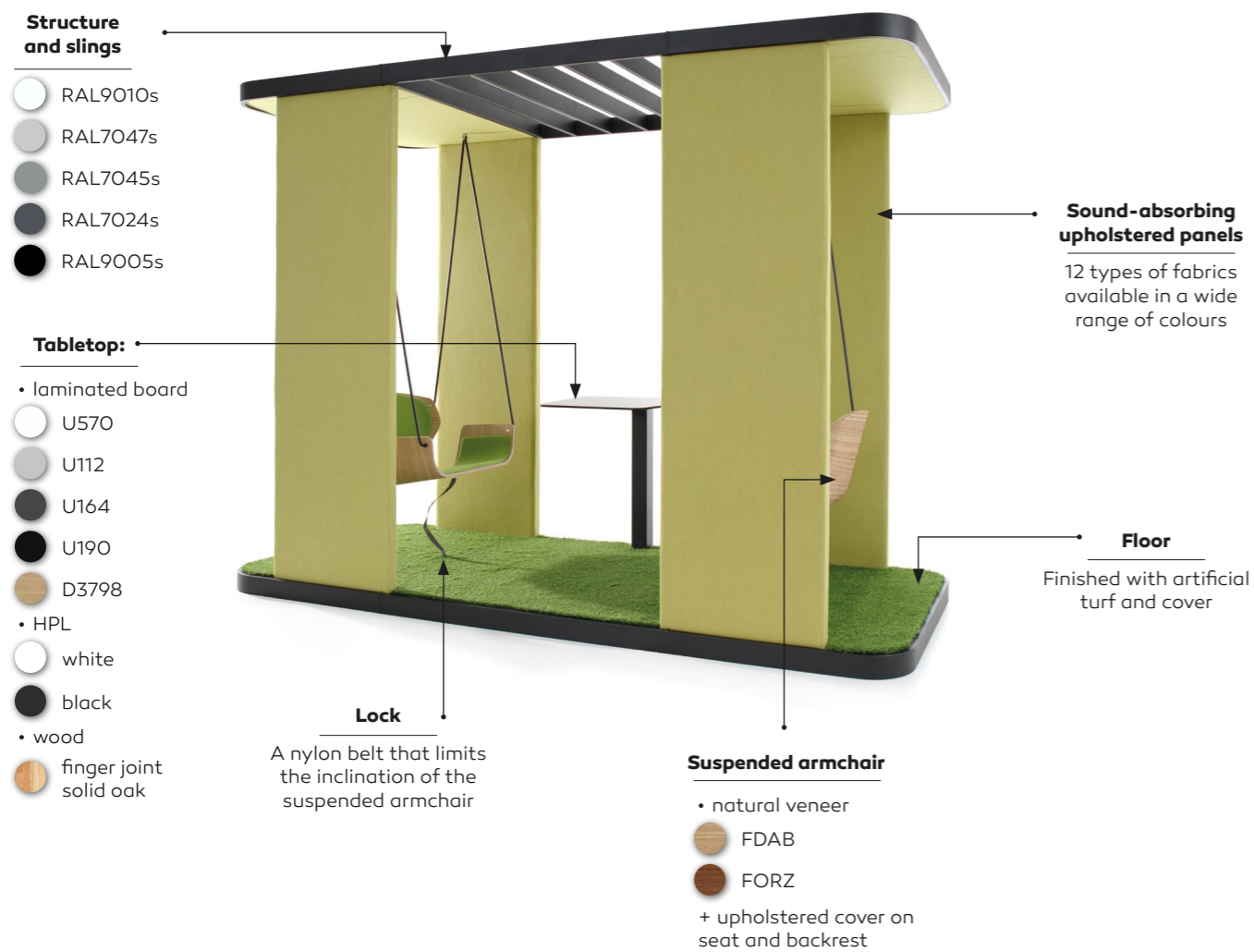

SUSPENDED ARMCHAIR



OPENWORK CEILING

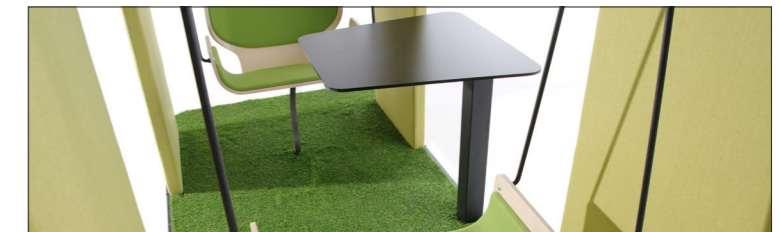

TABLE

## STRUCTURE

Metal structure, powder coated (structure) filled with HDF board, covered with foam and upholstered with fabric.

## SUSPENDED ARMCHAIR

Bucket made of coloured plywood. The cover on the seat and backrest is made of foam upholstered with fabric or leather. The armchair is secured with a nylon strap, attached to the floor, which limits tilt. The seat is hung on metal slings, powder coated, in the colour of the structure. Maximum load of one seat is 150 kg.

## TABLE

Table based on a metal, powder coated in the color of the structure.

## CEILING

Metal structure, openwork in the middle, on edges combined with a wooden structure. Foam-covered, upholstered with fabric from the bottom, from the top in standard wigofil (fabric for an extra charge).

## FLOOR

Wooden structure placed on a steel frame, finished with a cover in the colour of the structure, and artificial grass.

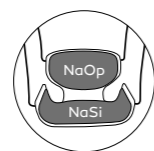
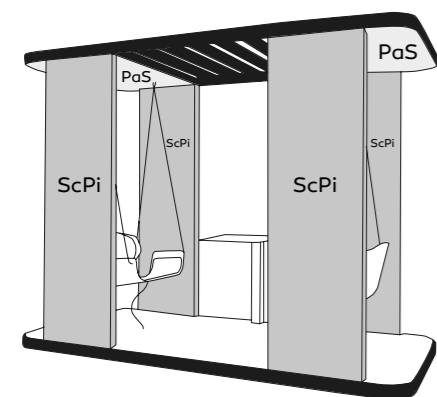

## UPHOLSTERING POSSIBILITIES

1. ScPi fabric colour – vertical walls
2. PaS fabric colour – ceiling panels
3. NaSi fabric colour – armchair seat cover  
NaOp fabric colour – backrest seat cover

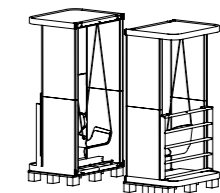
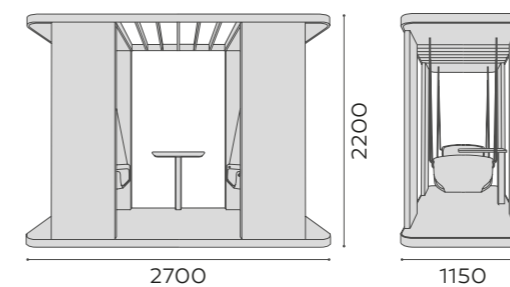

net weight of the product: 360

pallet I	pallet II
H: 2340	H: 2340
L: 920	L: 920
W: 1160	W: 1160

gross weight:	gross weight:
230 kg	205 kg

# social swing single

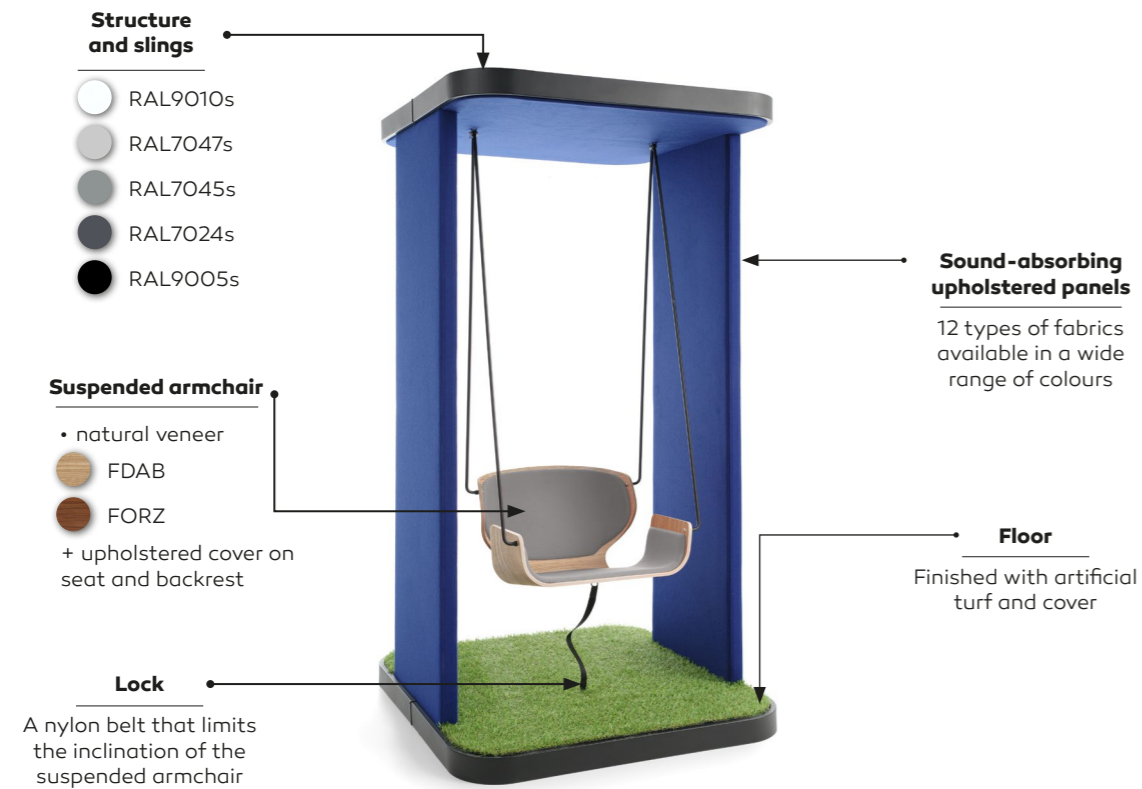

SUSPENDED ARMCHAIR



LOCK

## STRUCTURE

Metal structure, powder coated (structure) filled with HDF board, covered with foam and upholstered with fabric.

## SUSPENDED ARMCHAIR

Bucket made of coloured plywood. The cover on the seat and backrest is made of foam upholstered with fabric or leather. The armchair is secured with a nylon strap, attached to the floor, which limits tilt. The seat is hung on metal slings, powder coated, in the colour of the structure. Maximum load of one seat is 150 kg.

## CEILING

The wooden structure placed on a metal frame, covered with foam, upholstered with fabric from the bottom, from the top with a standard wigofil (fabric for an extra charge).

## FLOOR

Wooden structure placed on a steel frame, finished with a cover in the colour of the structure, and artificial grass.

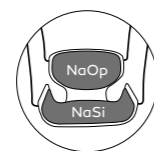
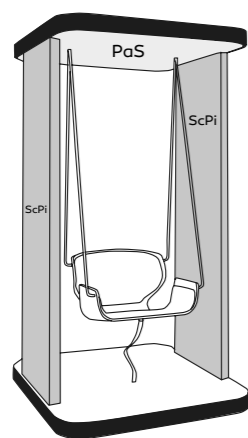

## UPHOLSTERING POSSIBILITIES

1. ScPi fabric colour – vertical walls
2. PaS fabric colour – ceiling panels
3. NaSi fabric colour – armchair seat cover  
NaOp fabric colour – backrest seat cover

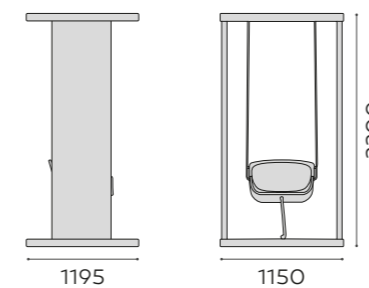

net weight of the product: 170

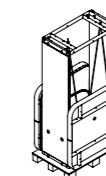

pallet I  
H: 2340  
L: 840  
W: 1170

gross weight:  
210 kg

# technical examinations

Social Swing has been tested in terms of strength of the supporting steel structure, loads, stability, compliance with office product standards. The product is safe and complies with standards:

- PN-EN 581-1:2017\_04,
- PN-EN 581-2:2016\_02,
- PN-EN 1728:2012,
- PN-EN 16139:2013\_07,
- PN-EN 12520:2016\_02,
- PN-EN 1022:2019-03.



Numerical analysis of social swing load-bearing structure



Tomasz Awłasewicz, MSc, Eng.

Grzegorz Gileta, MSc, Eng.

Extended version – February 2018

Calculations were made for: Office For Design Maciej Karpiak

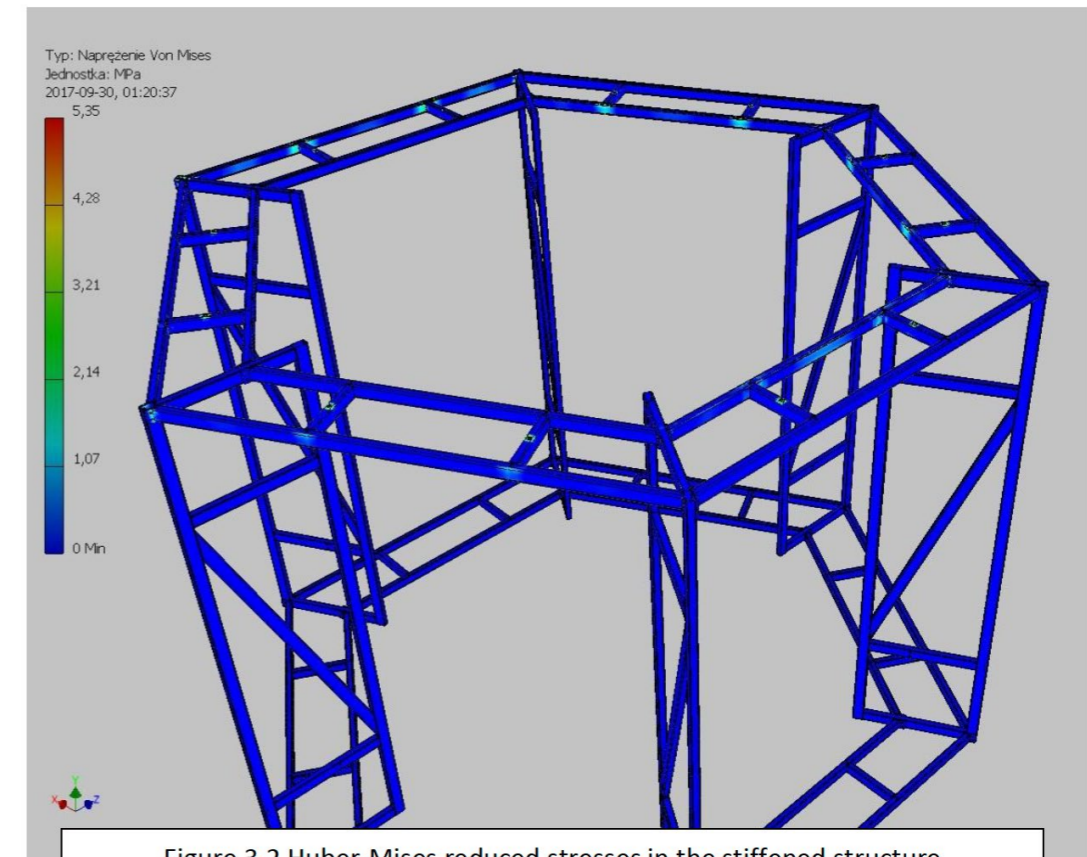

Figure 3.2 Huber-Mises reduced stresses in the stiffened structure

In order to visualize the improved stiffening of the structure, additional calculations were carried out for the loads according to VARIANT NO 2, using skew elements in the vertical trusses:

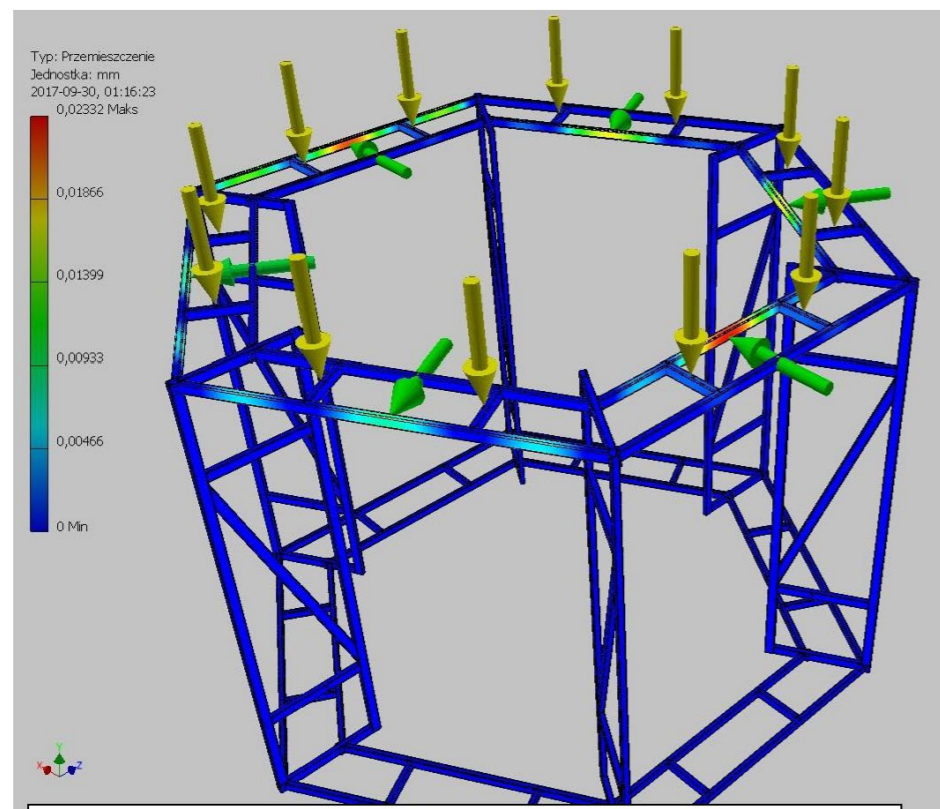

Figure 3.2 Absolute displacements in the stiffened structure

**SocialSwing**

Numerical strength calculations of a steel load-bearing structure

**FINAL CONCLUSIONS**

It is clear that the use of skew stiffeners of the vertical trusses has reduced over 30 times the reduced stresses in the structure and reduced almost **1000 times** the absolute displacement of the structure: from almost 23 mm to 0.023 mm.

In all calculation variants, despite the assumed significant dynamic safety factors, the stresses in the structure are below the assumed permissible stresses of 164.5 MPa.

The vector analysis of the forces has shown that the free-standing structure is not at risk of overturning under the assumed operating loads.

Tomasz Awłasewicz, MSc, Eng.  
Grzegorz Gileta, MSc, Eng.

inż. Grzegorz Gileta  
Up. Nr ZAP 00031/20K/11  
UPRAWNIENIA DO PRACOWNIA  
BEZ OGRANICZEŃ  
W SPECJALNOŚCI KONSTRUKCYJNO-BUDOWLANEJ

The full version of the numerical analysis of the social swing supporting structure is available for download at [www.bejot.eu](http://www.bejot.eu)

**TEST REPORT NO 39/17/S**

**REPORT 134/2018  
TEST OF A STIRRUP BOLT**

**1. Test subject and scope:**

Verification of compliance of furniture with standards

**2. Order number: RDM 45/A/17/S**

**3. Name and address of customer:**

**BEJOT Sp. z o.o.**  
63-112 Brodnica k/Poznań  
Manieczki, ul. Wybickiego 2a

**4. Designation and symbol of type of product/products covered by tests:**

**Social Swing**

**5. Test carried out in the period: 29/09/2017 – 04/10/2017**

**6. Identification of tested product/products covered by tests:**

Technical description and design drawing of the product

**7. List of standards on the basis of which the tests have been carried out:**

PN-EN 581-1:2017_04	PN-EN 16139:2013_07
PN-EN 581-2:2016_02	PN-EN 12520:2016_02
PN-EN 1728:2012	PN-EN 1022:2007

**8. Test results:**

The results of the strength and life tests are given in the sheets from 1-39/17/S to 4-39/17/S to the test certificate No 39/17/S.

The test results presented in this report only apply to the tested samples. The test report may not be copied in part or whole.

**9. Assessment of test results:**

**The above products comply with the standard requirements.**

Director of the Laboratory of Furniture Testing  
and Certification  
*Illegible signature*  
Karol Łabęda, M Sc. Eng

Director of the Furniture Department  
*Illegible signature*  
Prof. Jerzy Smardzewski

Stamp "University of Natural Sciences in Poznań, Department of Furniture, Laboratory of Furniture  
Testing and Certification, ul. Wojska Polskiego 38/42, 60-627 Poznań"

Poznań, 4<sup>th</sup> October 2017

**1. SUBJECT OF TEST**

The subject of the test was a M 10 screw ended with a stirrup with a bolt  $\varnothing$  10.  
After the test the sample was marked: Al/02/18

**2. CUSTOMER**

ABAKOSTEEL S.C.  
Mr Robert Maniak  
84-300 Lębork, ul. Artylerzystów 4a  
Order dated 26/02/2018

**3. PURPOSE OF TEST**

Measurement of the static breaking load of the component described in par. 1.

**4. TECHNICAL CONDITIONS OF TEST**

The test was performed on 28/02/2018.

For the load test, a vertical three-range testing machine for static tensile strength tests up to 100 kN was used, mark ZDM 10/91, serial number 2214/18, manufactured by WPN Rauenstein. Range B up to 50 kN was applied.

Two tests were carried out. The tested part was fastened from the thread side each time using a GP M10 eye nut. In the first test, the tested part was clamped with a flat bar (4.5 mm wide) with an opening of  $\varnothing$  11 (photograph No 1), and in the second test with a chain connector (10 mm wide).

**5. RESULT OF TEST**

First test: flat bar system – the recorded tensile strength was 33.8 kN (i.e. approx. 3,446.58 kG); the broken element was the flat bar which fastened the test piece. The tested part was slightly deformed, but it did not break.

Therefore, a second test was carried out where, instead of a flat bar, a chain connector was fastened. In this case, a force of 44.8 kN (i.e. approx. 4,568.25 kG) was recorded, while the broken element was the middle part of the thread (except for the fastening in the eye nut).

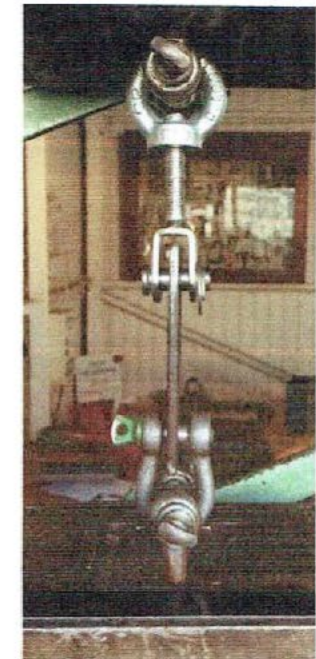

Photograph 1: Fastening arrangement in the first test

Stamp "Head of the Laboratory, Mateusz Kowalski, Owner"  
*Illegible signature*

REGON Statistical No: 365522218, Tax No: 9721117518, Bank Zachodni WBK S.A., 1st Branch in Suchy Las,  
62 1090 1463 0000 0001 3341 1648  
www.lbkz.pl, e-mail lbkzh@poczta.onet.pl



**[www.bejot.eu](http://www.bejot.eu)**

Bejot Sp. z o.o. ul. Wybickiego 2A Manieczki 63-112 Brodnica n. Poznań  
tel. +48 (61) 281 22 25 fax +48 (61) 281 22 54 e-mail: [biuro@bejot.eu](mailto:biuro@bejot.eu)

10/2020