

leaf_pod

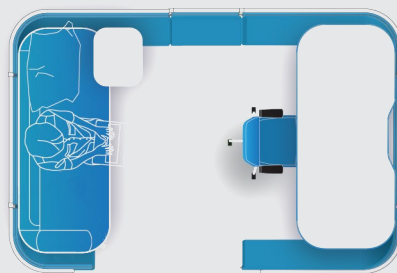

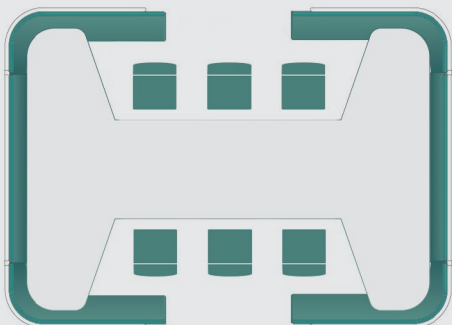
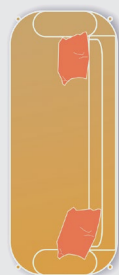
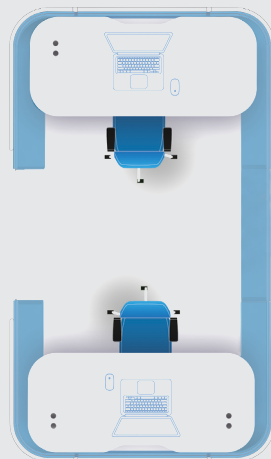
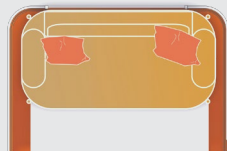
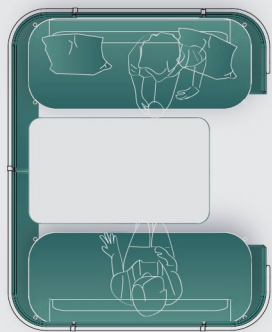

Dymitr Malcew

Polish designer, a graduate in architecture and urban planning at Gdańsk University of Technology.

The latest collection of furniture is a continuation of the cooperation between Dymitr and Bejot. Both Leaf Pod and the previously designed Treehouse, Beachhouse and Cave refer to nature. Due to their original shapes – a tree house, a beach basket and a cave – they evoke nice associations and serve to build a creative team.

Malcew's aspirations in his creative work are aimed at blurring the boundaries between office and home, work and rest, private and public space. This is also the case with the latest collection – Leaf Pod.

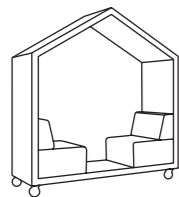

Treehouse

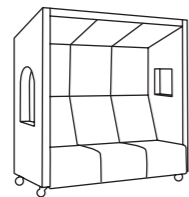

Beachhouse

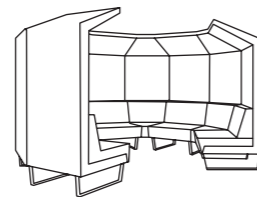

Cave

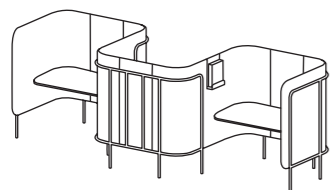

Leaf Pod

leaf_pod philosophy

It is said that work is a second home, mainly referring to the amount of time we spend at work. Just like at home, the office space should be properly arranged so that employees can perform their duties effectively. The aforementioned working time is a pretext to separate zones – for concentration, meetings, rest and meals.

The answer to these expectations is the new collection of Bejot office furniture designed by Dymitr Malcew. The designer was inspired by an enveloping leaf, which is reflected in the proposed style of the furniture set – its blurred, delicately rounded shapes bring to mind positive and warm associations. Particularly in open-plan offices, modules with partition walls are perfect for separating private space and organizing the surrounding space. An additional advantage of the collection is its good acoustic properties guaranteed by extensive wall surfaces and properly selected upholstery materials, available in warm and cool colours.

The collection has been designed in such a way that it is possible to connect individual modules, thanks to which it is possible to separate as many as 3 different zones, including work, collaboration, recharge, each consisting of enveloping shapes and an open, natural space.





RECHARGE

COLLABORATION

WORK

work

An open-plan office with a private space for individual work is no longer a dream, but a reality at your fingertips. Various modules, including the ones made of partition walls and a roof (with good acoustic properties), desks or sofas, can be freely combined to create a place conducive to increased concentration.

The work zone designed by Dymitr Malcew, created mainly for working in silence, is full of new ideas and original implementations. A space with an original appearance, high-quality workmanship and ergonomics, is essential today in every modern office – also in yours.

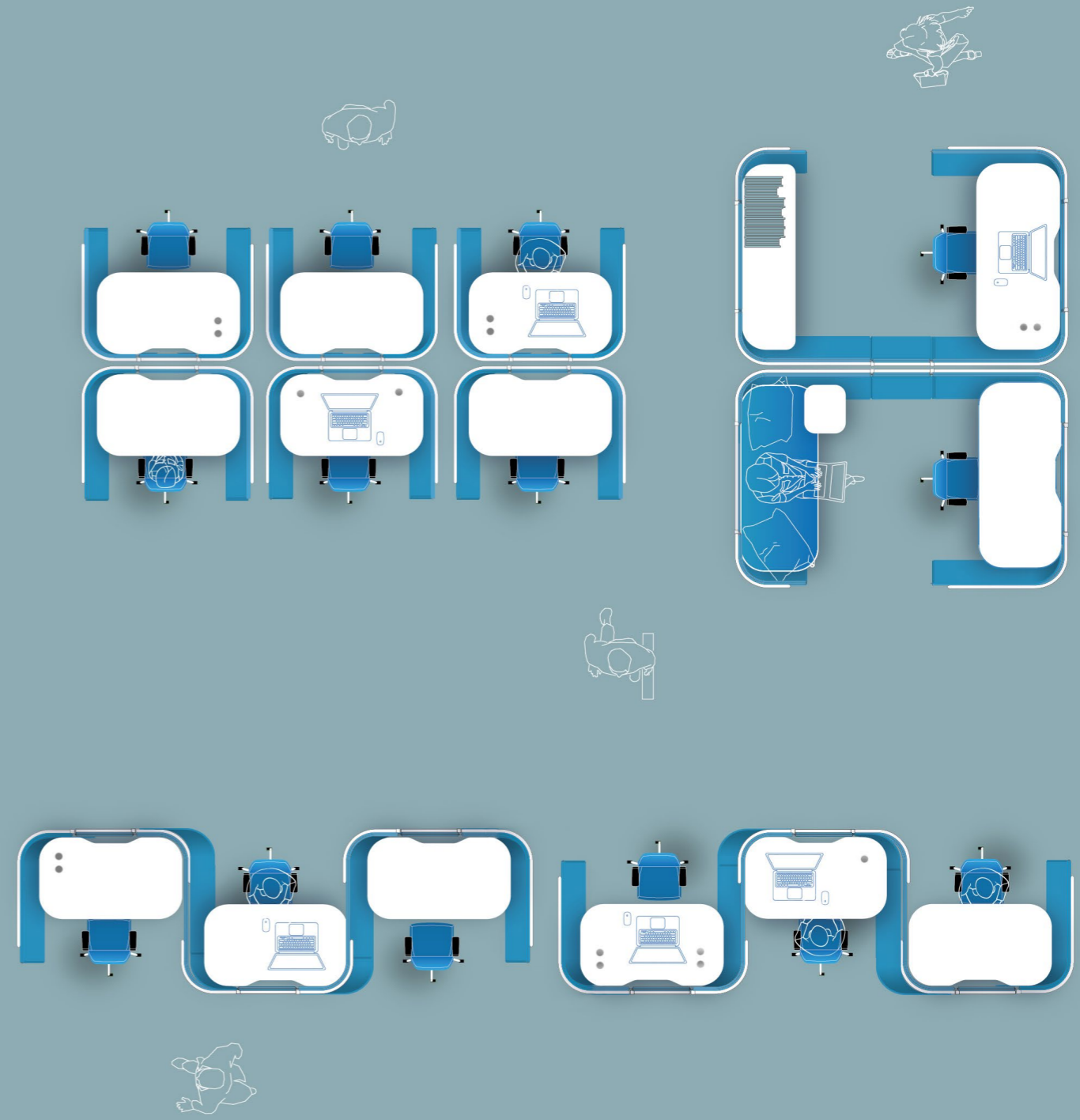

FOCUS POD S H1



FOCUS POD S



LDS65

FOCUS POD M



FOCUS POD M



LDS65

FOCUS POD XL



FOCUS POD XL

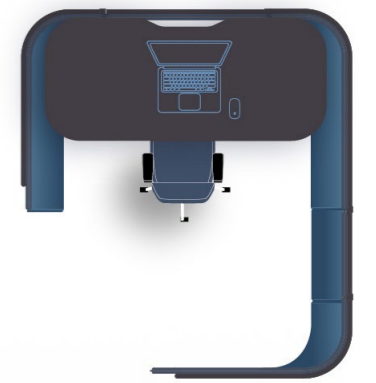

CUZ62

FOCUS DOUBLE POD W2



FOCUS DOUBLE POD

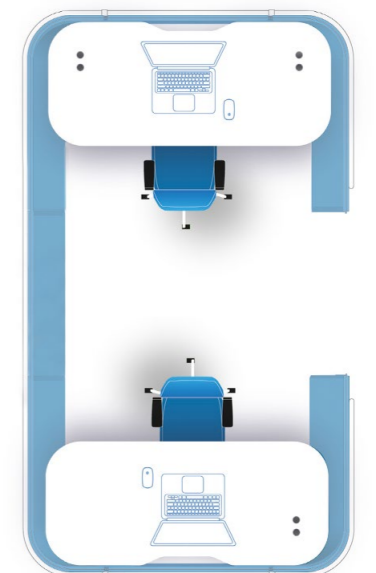

LDS55

MANAGER POD 1 H1



MANAGER POD 1



LDS63

STAND POD H3



STAND POD H3



CUZ65

MANAGER POD 2 H1



MANAGER POD 2

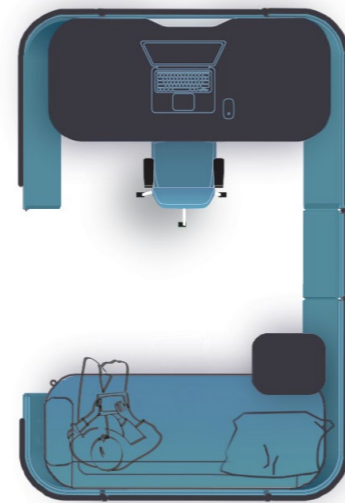

CUZ1W

SNAKE POD H1



SNAKE POD



LDS62

collaboration

The key to success in business is a well-coordinated team that can talk to each other. That is why Bejot has gone a step further. Now meetings do not have to be held only in closed spaces, which are not always conducive to creativity. The new collection of office furniture allows you to combine modules as needed.

Brainstorming is best done on couches facing each other, so that everyone can see and hear the conversation participants perfectly. The progress of a project, which requires concentration, can be checked in a zone separated from the rest of the office by a wall with a roof, where there is also a table and a sofa. There are many possibilities.

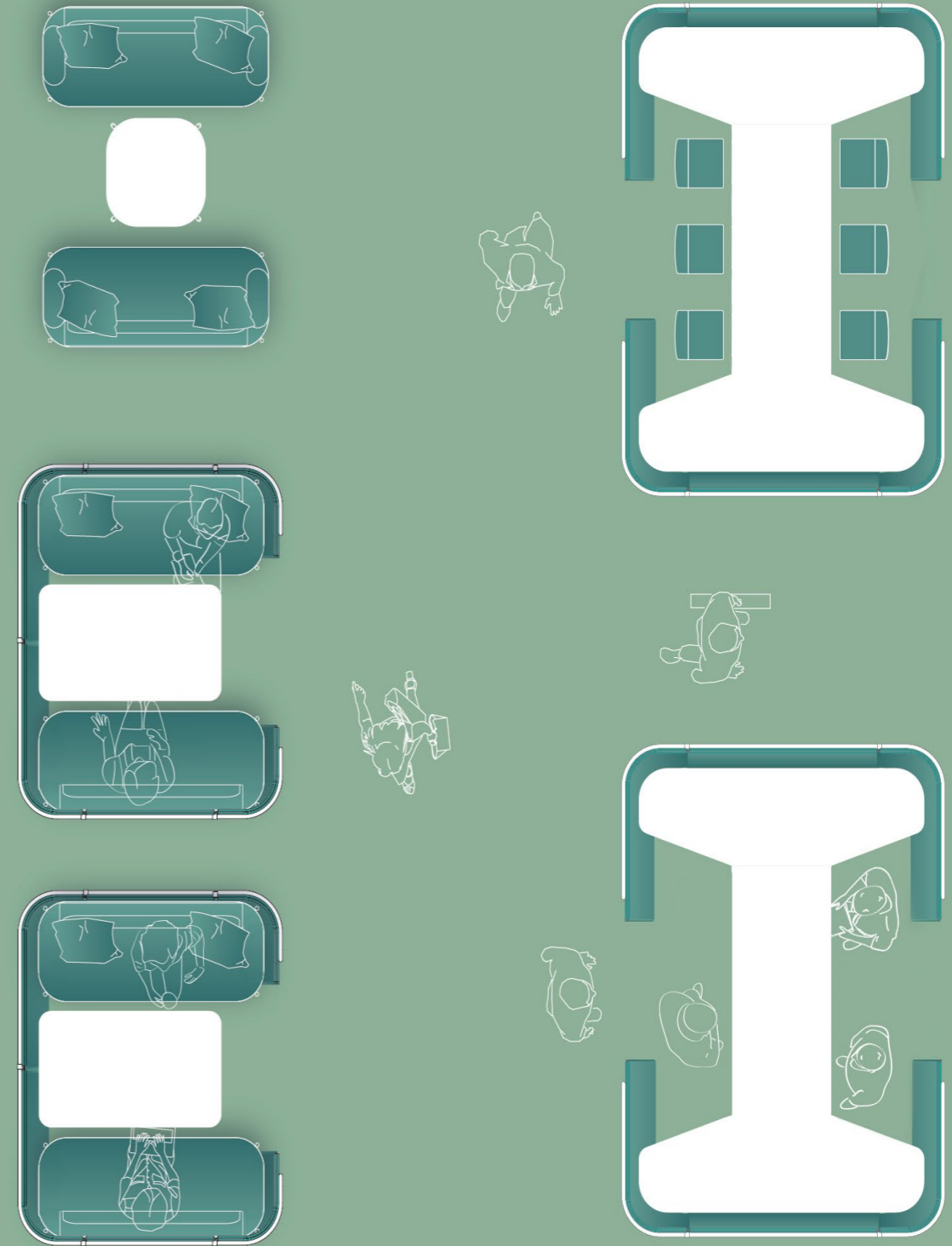

CHAT POD 1 H1



CHAT POD 1

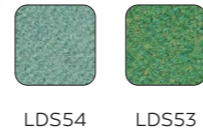
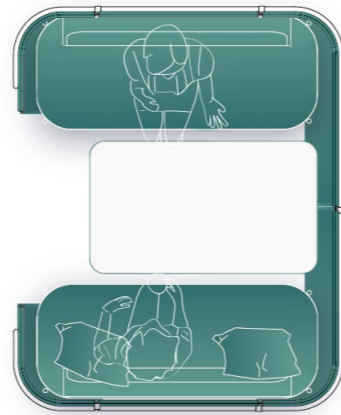

BRAINSTORM POD H3



collaboration

CHAT POD 2 H2



CHAT POD 2

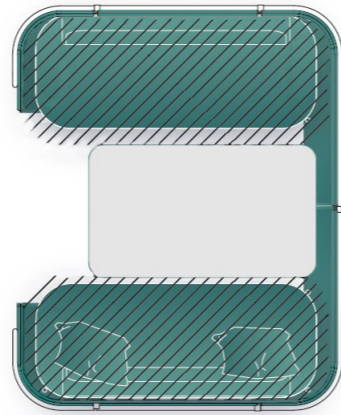

BRAINSTORM POD

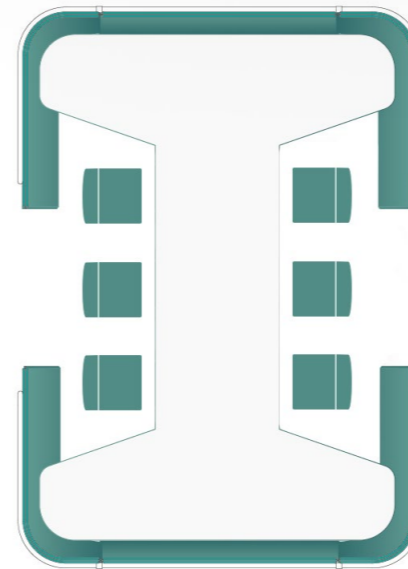

recharge

Occupational hygiene also means the ability to rest. Inhale – exhale... It's good to take a deep breath. The mind calms down, the body relaxes. The relaxation zone is a place where you can stop for a moment, not think about your duties or, under favorable circumstances, consider solving a pressing problem.

It is a place of regeneration, balance between rest and working at full capacity. What matters is here and now. Modules of any configuration, consisting of sofas and a couch, organize an informal office zone where everyone can feel at ease.

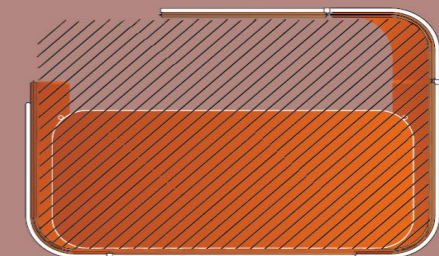
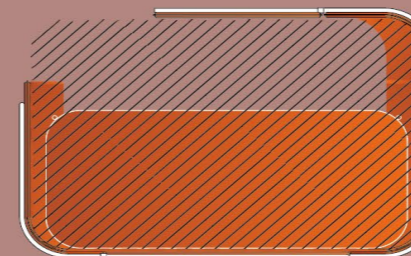
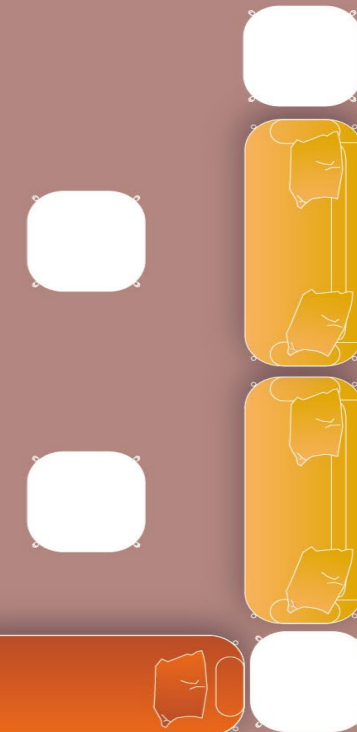
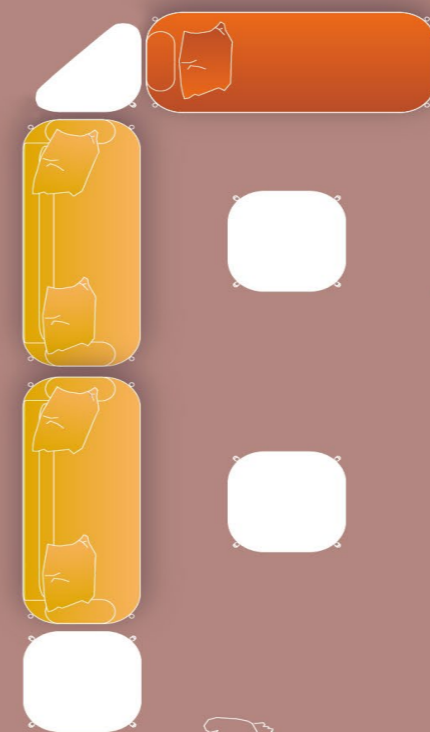
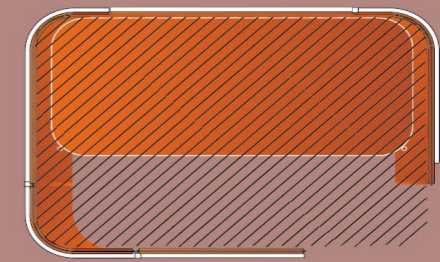
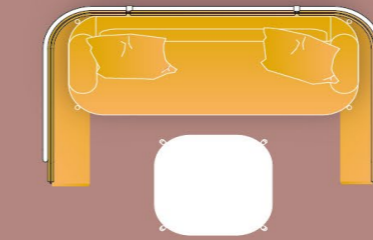

SOFA POD S H1



SOFA POD S

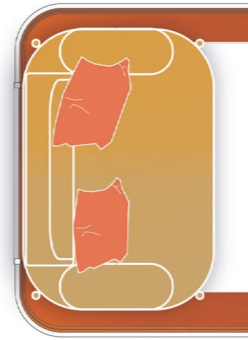

SOFA POD M

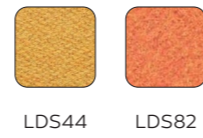
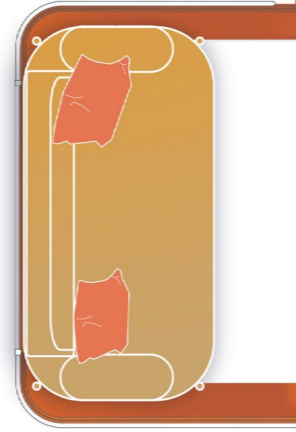

LDS44 LDS82

RECHARGE POD H2

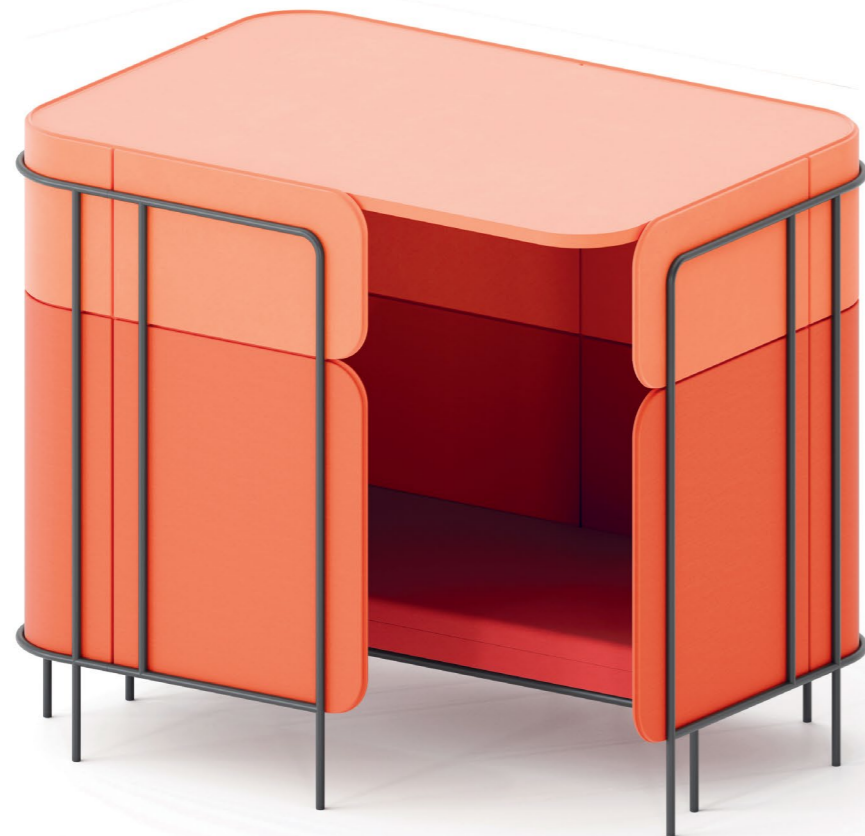

RECHARGE POD

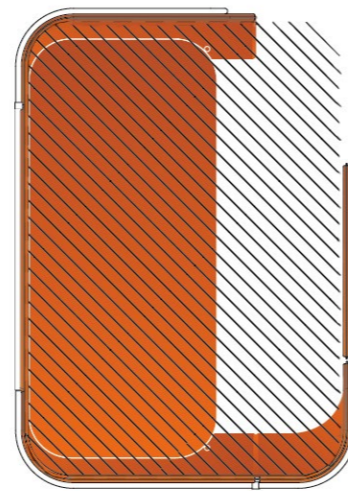

LDS82 LDS81 LDS80

SOFA FREE



LP SFF 112

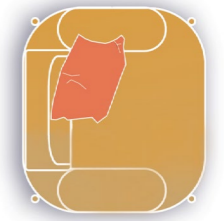

LP SFF 301



LP SFF 332

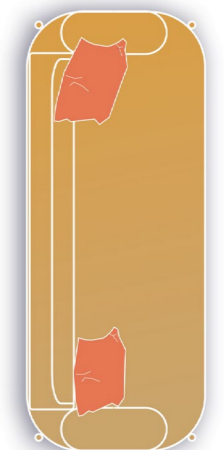

recharge

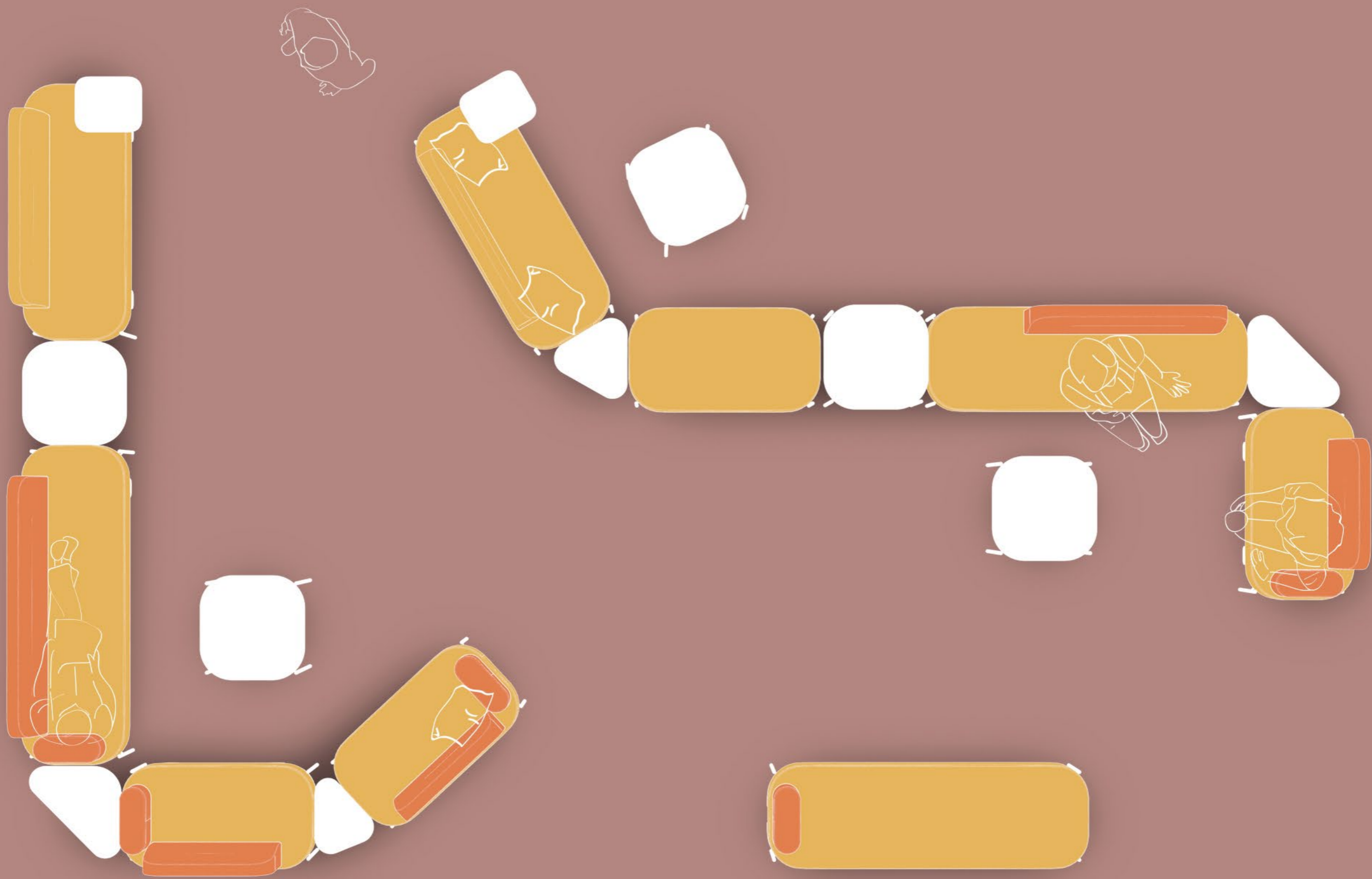

SOFA FREE



LP SFF 100



LP SFF 111L



LP SFF 220 + TB 410 M



LP SFF 320



LP SFF 331P



LP TB F650

SOFA FREE



TABLETOPS – SOFA CONNECTORS



LP LTB45
(connection of 2 sofas at an angle of 45°)

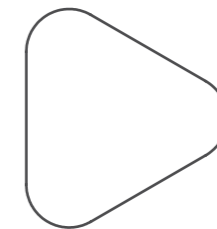

LP LTB60-2
(connection of 2 sofas at an angle of 60°)

LP LTB60-3
(connection of 3 sofas at an angle of 60°)

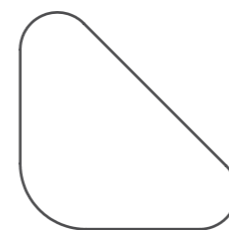

LP LTB90
(connection of 2 sofas at an angle of 90°)

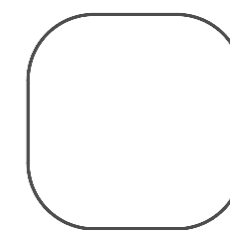

LP LTB180
(connection of 2 sofas in linear line)

configurations

sample leaf_pod sets

manager pod 1

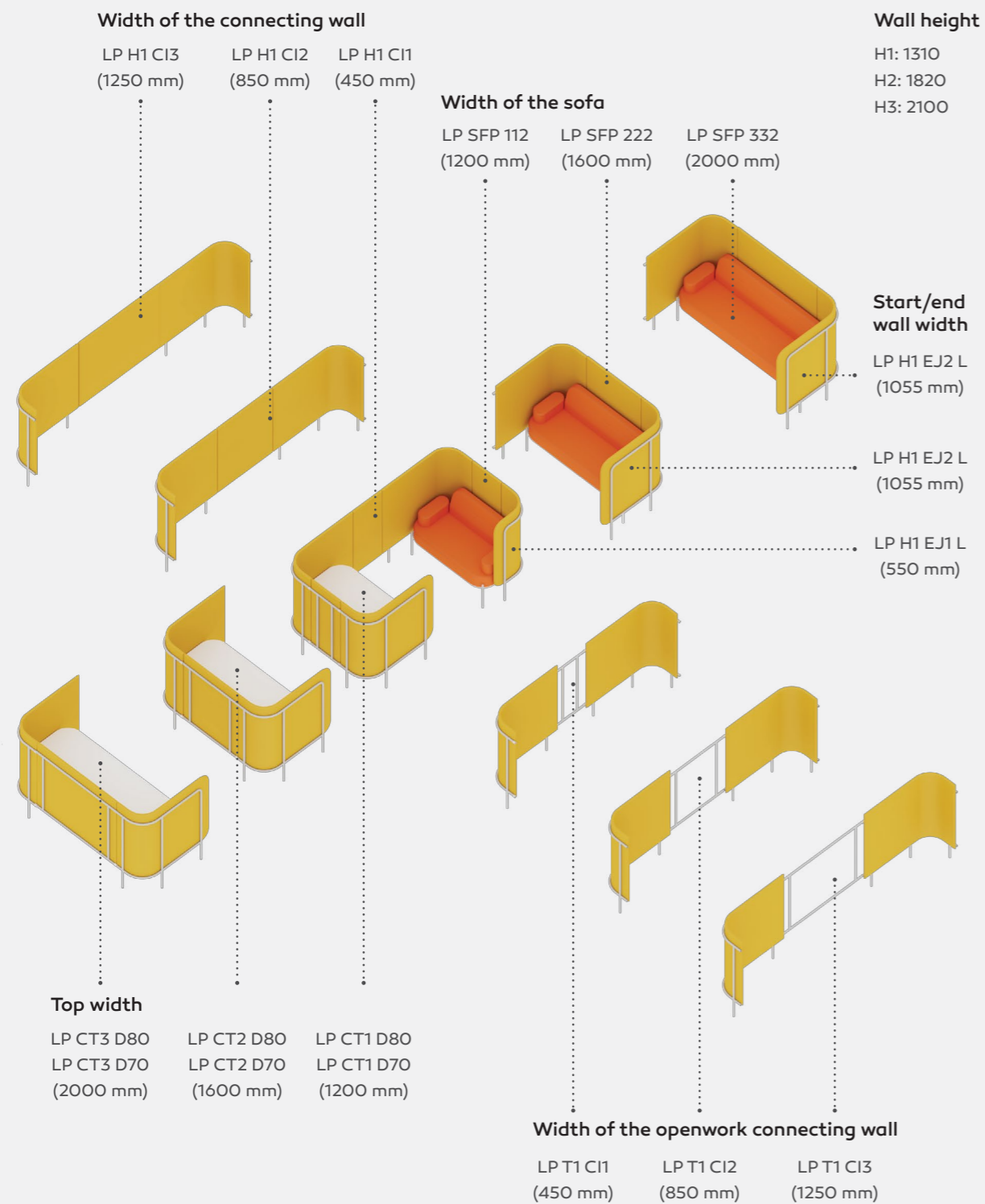

chat pod 2

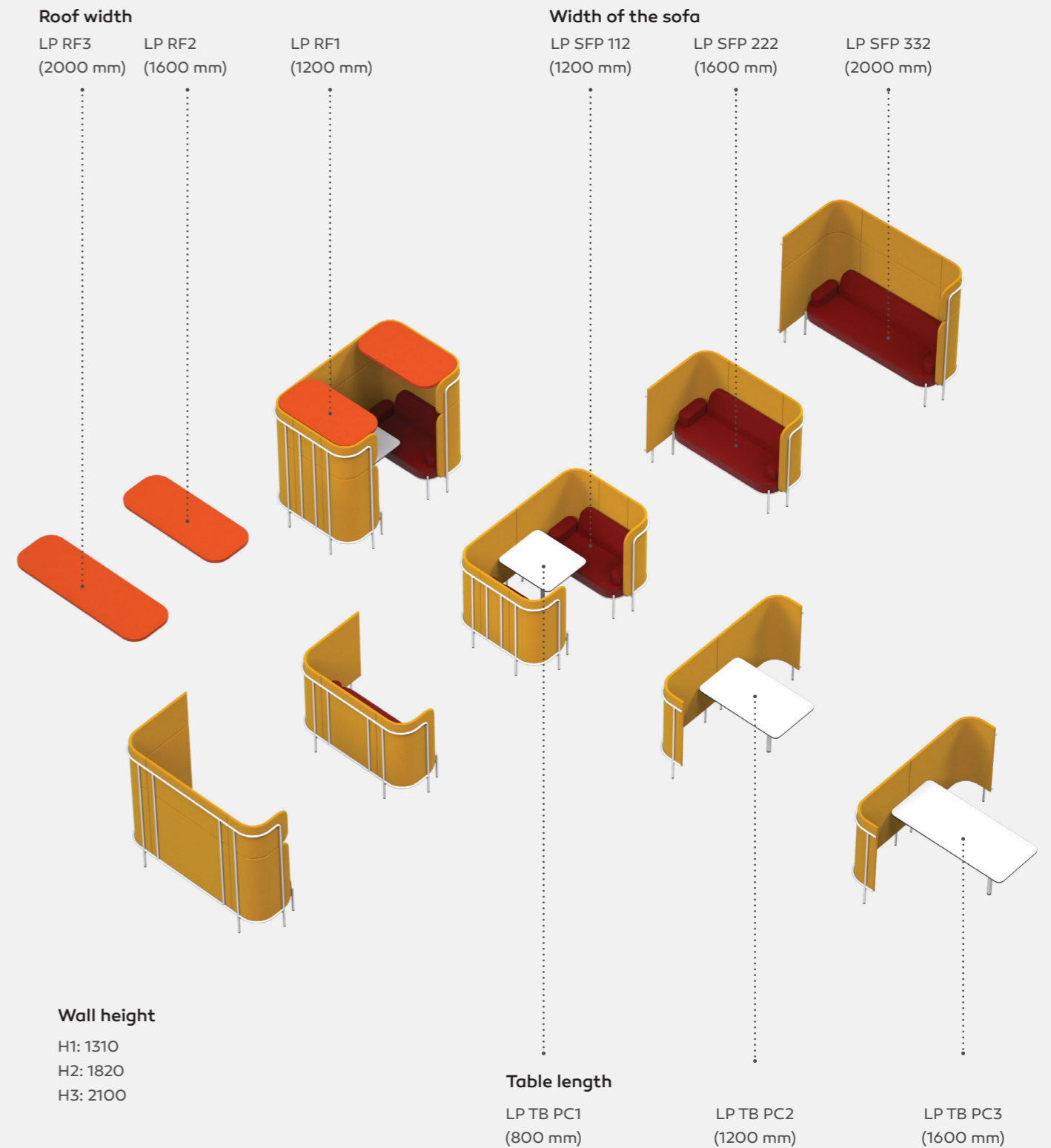

technical data



accessories (option)

accessories hung on the top of the wall (upholstered part)



LP OPK
pen container,
key hanger*
250x351,5x100 mm



LP ODL
document stand,
holder for pens*
250x351,5x100 mm

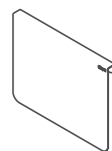
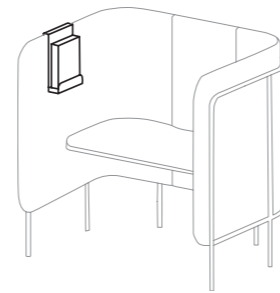

LP OMB
magnetic board*
450x351,5x40 mm



LP OOH
clothes hanger*
80x351,5x60 mm

* powder painted in the colour of the Leaf Pod wall frame

cable cover for walls (option)

accessories hung up on the metal wall structure



LPCM V H1
100x910x30 mm



LPCM V H2
100x1430x30 mm



LPCM V H3
100x1710x30 mm

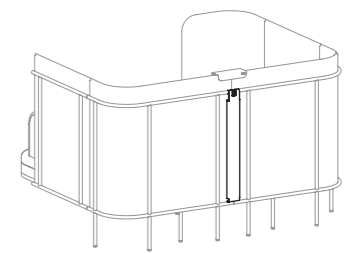

cable cover under a tabletop (option)

recommended when choosing a mediaport

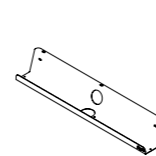

LPCM H S
76x10x13 mm

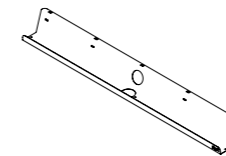

LPCM H L
116x10x13 mm

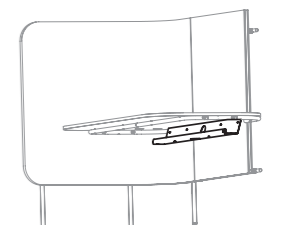

module holders (option)

accessories hung on the top of the wall (upholstered part)



LP TV H1
190x430x60 mm

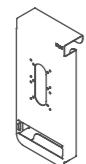

LP TVM H1
260x560x100 mm



LP TV H2
190x950x60 mm



LP TVM H2
260x1080x100 mm

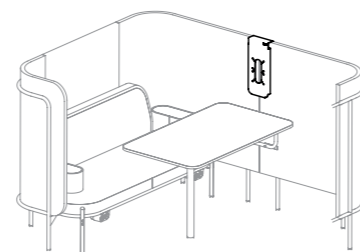

LP TV H3H
190x650x60 mm

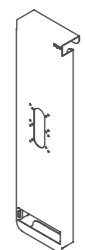

LP TVM H3H
260x1000x100 mm



LP TV H3L
190x1230x60 mm



LP TVM H3L
260x1360x100 mm

power and data modules (option)

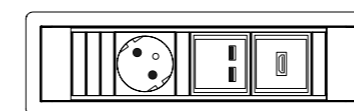

LP [type] 3VHCC*
mediaport for hangers
1 voltage socket 230 V, 1 x HDMI, 2x USB

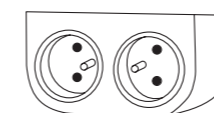

LP [type] 2VV*
mediaport mounted to the sofa (on the right, on the left or on both sides)
white (W) or black (B) with 2 voltage sockets 230V

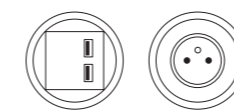

LP [type] 1V* / LP M1CC
round PIX mediaport white (W) or black (B) mounted to the tabletop
LP [type] 1V – 1 voltage socket 230 V
LP M1CC – 2 x USB charger



IC
Inductive charger black mounted to the tabletop

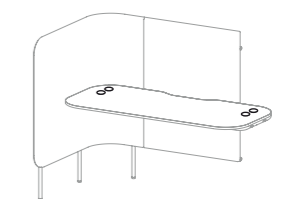
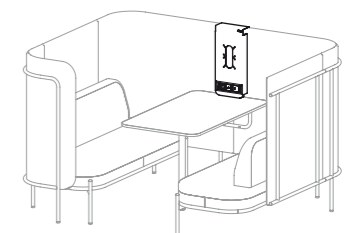

* type E – Poland, France / type F – Germany / type G – United Kingdom

cushions



PP G
cushion
50x50 mm



PP G
cushion
60x40 mm

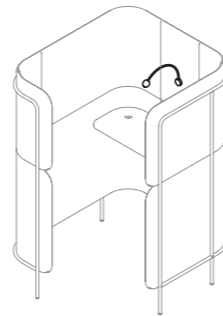

lights



pinspot LED 120 Lm**
in black (B) or white (W) colour, for stand_pod and recharge_pod sets (standard)
complete with a power supply, a grommet and a metal masking frame LP CMVH3 outside
the leaf_pod set
type E – Poland, France / type F – Germany / type G – United Kingdom

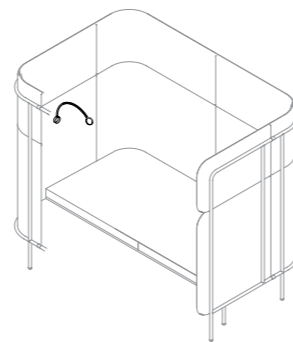

construction

powder painted

base of the sofa

powder painted (standard) or wooden (option)

metal structure



RAL 9010s **RAL 7047s** **RAL 7045s** **RAL 7024s** **RAL 9005s**

ash wood



J1 **J2** **J3** **J4**

tables

laminated board



U570 **U112** **U164** **U190** **D3798**

HPL



white with a black core **black with anti-fingerprint surface**

feet

- LK – adjustable feet for ceramic, concrete and carpet floors (standard)
- LF – adjustable felt feet for wooden floors and panels (option)

leaf_pod wall colours

fabrics – blazer

composition: virgin wool 100%, weight 460g/m² ±5%; abrasion resistance: 65 000 Martindale cycles (BS EN ISO 12947-2:2016); pilling: >3 (UNI EN ISO 12945/2:2000); light fastness: 5 (BS EN ISO 105:B02:2014-BS6); fastness to rubbing: wet 4-5 (BS EN ISO 105-X12:2016) dry 4-5 (BS EN ISO 105-X12:2016); flammability: BS EN 1021-1:2014, BS EN 1021-2:2014, BS7176:2007 Low Hazard, UN 9175:2010 11M, NFD60-013



CUZ21 **CUZ90** **CUZ63** **CUZ18** **CUZ39** **CUZ2W** **CUZ1L** **CUZ1K** **CUZ1N** **CUZ1W**



CUZ09 **CUZ02** **CUZ1R** **CUZ28** **CUZ1E** **CUZ31** **CUZ30** **CUZ67** **CUZ12** **CUZ08** **CUZ62**

fabrics – synergy

composition: 95% virgin wool, 5% polyamide; weight: 400g/m² ±5%, abrasion resistance: 100 000 Martindale cycles (BS EN ISO 12947-2:2016); pilling: 4 (BS EN ISO 12945-2:2000); light fastness: 5 (BS EN ISO 105-B02:2014-BS6); fastness to rubbing: wet 4 (UNI EN ISO 105-X12), dry 4 (UNI EN ISO 105-X12); flammability: BS EN 1021-1:2014, BS EN 1021-2:2014, BS 7176 Low Hazard, UN 9175:2010 Class 1 IM, ÖNORM B 3825 & A 3800-1



fabrics – synergy STUDIO DESIGN (extended delivery time)

composition: 95% virgin wool, 5% polyamide; weight: 400g/m² ±5%, abrasion resistance: 100 000 Martindale cycles (BS EN ISO 12947-2:2016); pilling: 4 (BS EN ISO 12945-2:2000); light fastness: 5 (BS EN ISO 105-B02:2014-BS6); fastness to rubbing: wet 4 (UNI EN ISO 105-X12), dry 4 (UNI EN ISO 105-X12); flammability: BS EN 1021-1:2014, BS EN 1021-2:2014, BS 7176 Low Hazard, UN 9175:2010 Class 1 IM, ÖNORM B 3825 & A 3800-1



fabrics – silvertex

surface: 100% vinyl; vinyl backing: 100% polyester Hi-Loft 2™; weight: 685g/m²; fastness to rubbing: 300 000 Martindale cycles (EN ISO 12947-2:1999); light fastness: Xenotest (DIN 54004)-7; flammability: EN 1021 Part 162:2015, EN 71-2:2006+A1:2007, DIN 4102 B2, NF P 92-503/M2, UNI 9175 (1987)/UNI 9175/FA1 (1994) Classe 1.IM, (MED) Council Directive 96/98 EC on marine equipment, IMO A 652 (16) Annex I, 8.2 and 8.3, other: EN 71-3:2006+A1:2007



fabrics – silvertex STUDIO DESIGN (extended delivery time)

surface: 100% vinyl; vinyl backing: 100% polyester Hi-Loft 2™; weight: 685g/m²; fastness to rubbing: 300 000 Martindale cycles (EN ISO 12947-2:1999); light fastness: Xenotest (DIN 54004)-7; flammability: EN 1021 Part 162:2015, EN 71-2:2006+A1:2007, DIN 4102 B2, NF P 92-503/M2, UNI 9175 (1987)/UNI 9175/FA1 (1994) Classe 1.IM, (MED) Council Directive 96/98 EC on marine equipment, IMO A 652 (16) Annex I, 8.2 and 8.3, other: EN 71-3:2006+A1:2007



acoustic properties



attenuation absorption

Leaf_pod walls mark places of workstations and meetings, additionally ensuring high sound attenuation parameters. It is a significant parameter when choosing partition walls, because acoustic waves propagate into the remaining areas of the office to a lesser extent, and the range of audibility of conversations is reduced. This allows for effective work, maintaining a state of high concentration, as well as for comfortable meetings.

The structure is covered with a special, flame-retardant, sound-absorbing non-woven fabric, which effectively reduces the noise level in the office and reduces the reverberation time. The sound-absorbing material used in the Leaf Pod construction, thanks to its large surface, can effectively replace several wall panels.

measurement of the sound absorption coefficient in a reverberation chamber according to PN-EN ISO 354:2005, ISO 20189:2018*

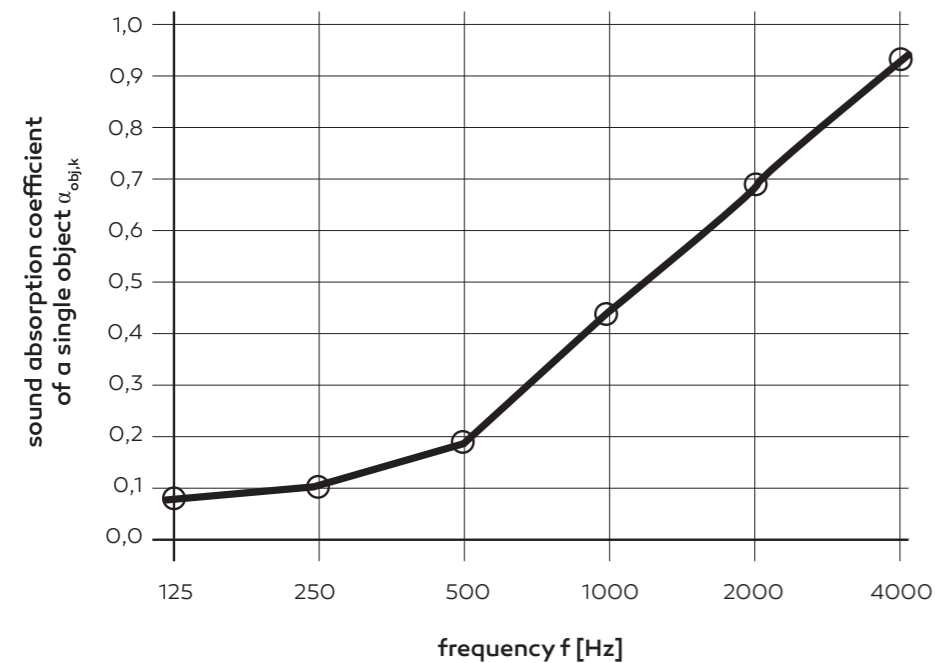

* tests for sample of leaf_pod panel 1600x650x30. The result may vary depending on the fabric selected.

panel cross-section

A B C B A



- A fabric
- B acoustic non-woven fabric
- C insulating core

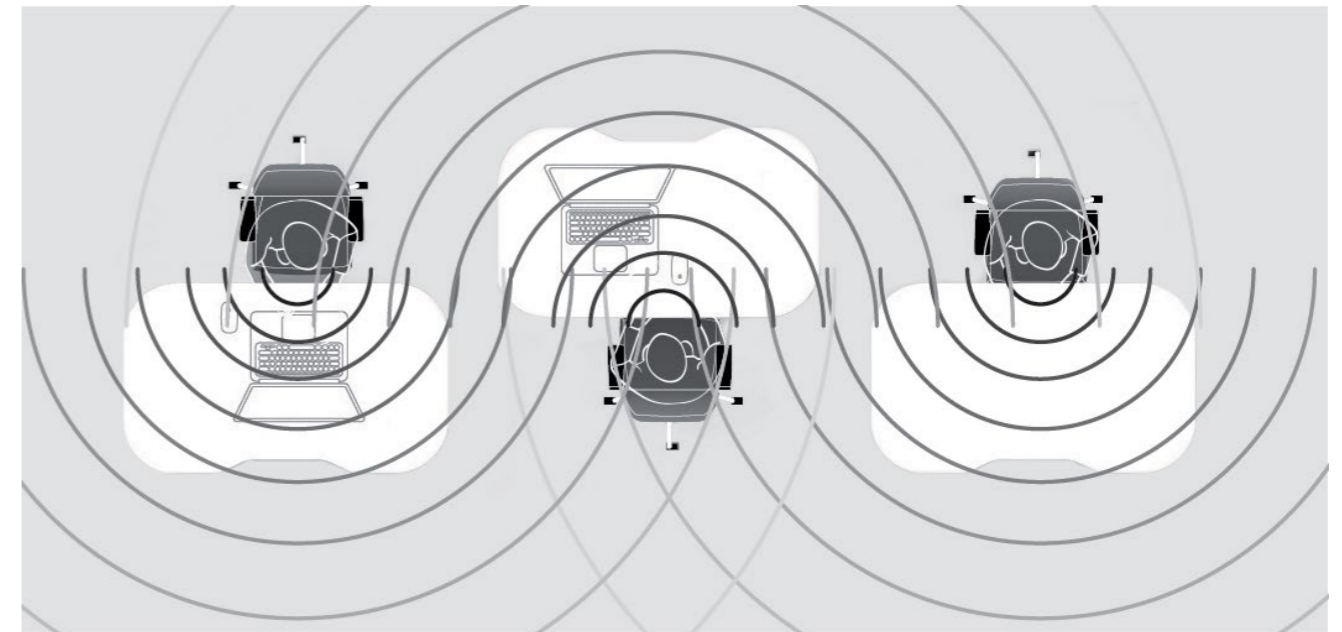

Arrangement of desks in an open space office without acoustic solutions.

Acoustic waves spread without any obstacles, there is noise in the office, conversations are heard even at a great distance – this fact has a negative impact on the concentration of office users.

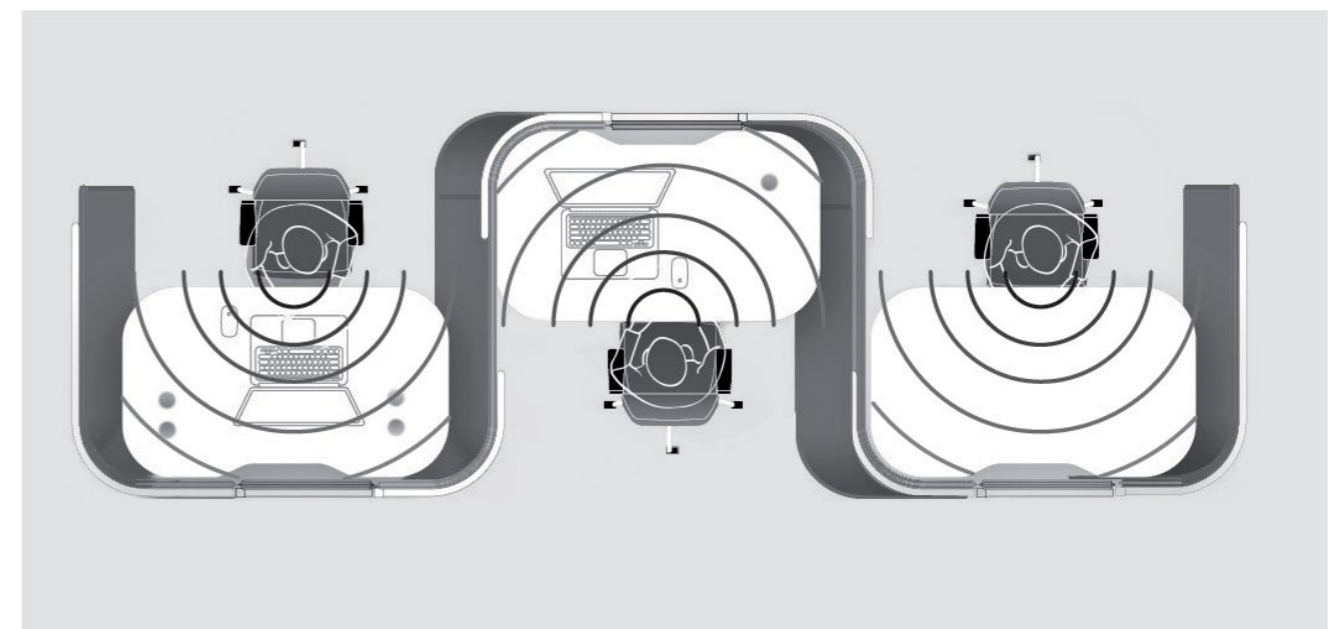

Arrangement of desks in an open space office with Leaf Pod acoustic walls.

The walls of the Leaf Pod structure are an effective obstacle on the path of acoustic waves – the noise level is lower, conversations propagate to other work stations to a lesser extent. The office is quieter and its users can work in full concentration.

summary of set dimensions

LP FOCUS POD S H1

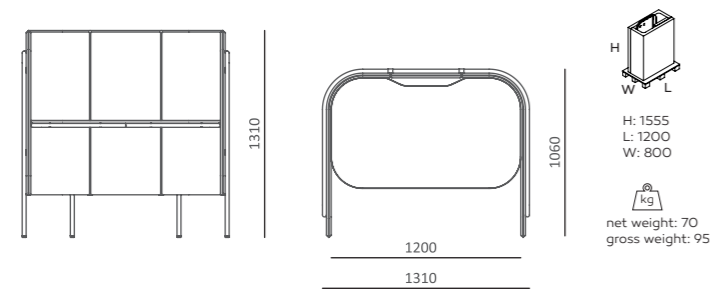

LP DOUBLE POD H1

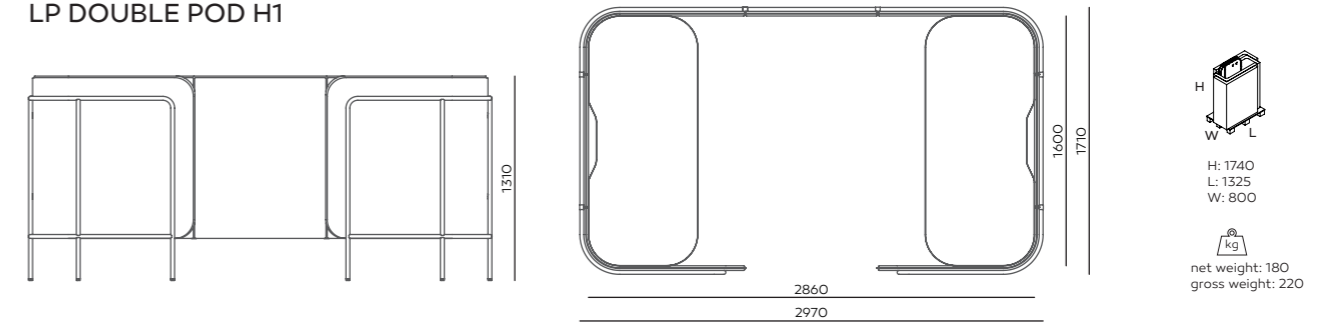

LP FOCUS POD M H1

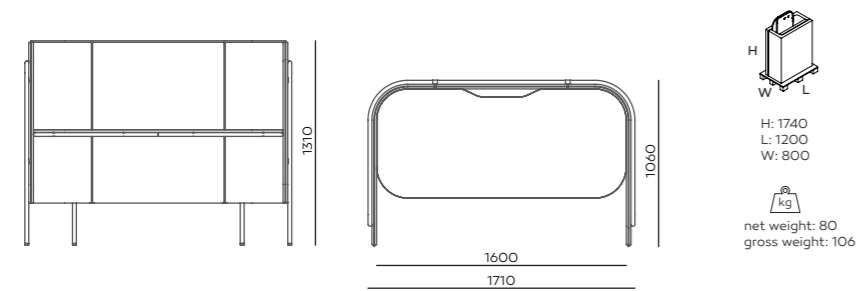

LP MANAGER POD 1

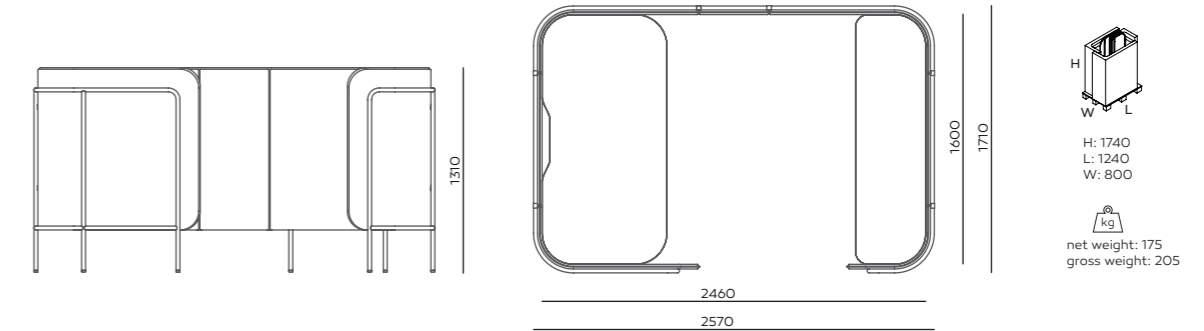

LP FOCUS POD XL H1

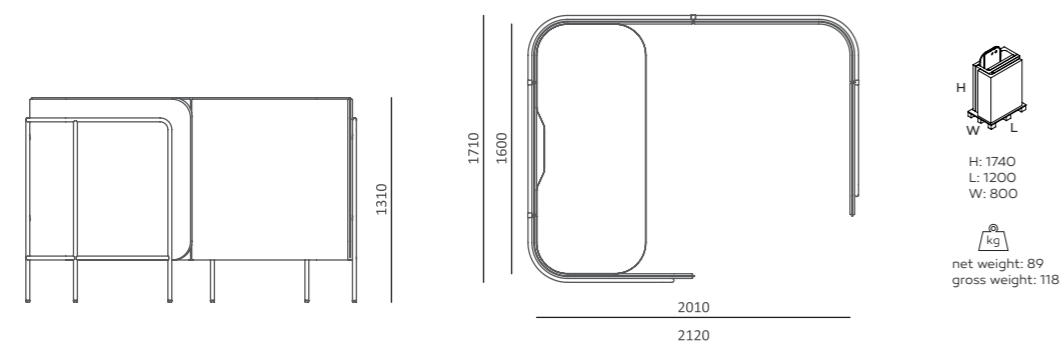

LP MANAGER POD 2

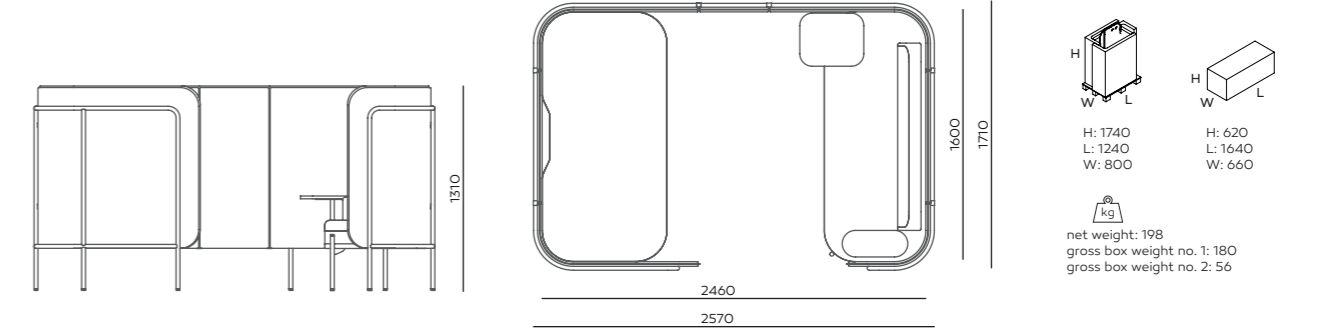

LP DOUBLE POD W2

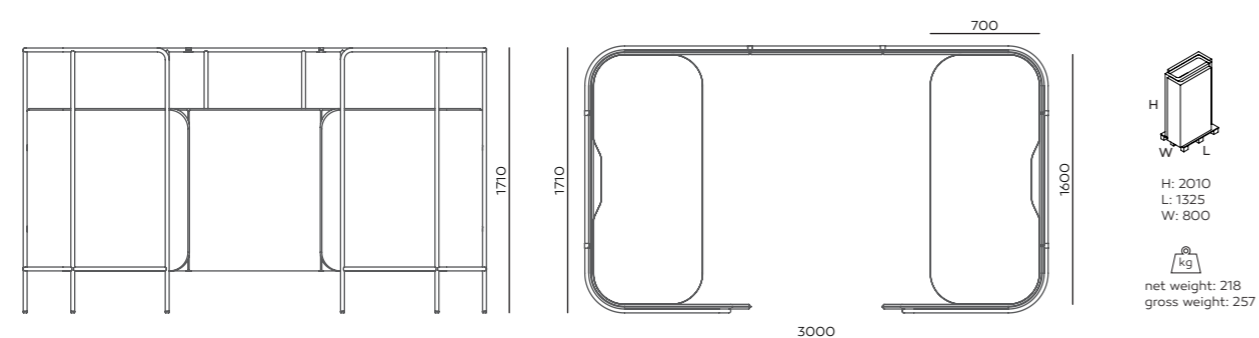

LP STAND H3

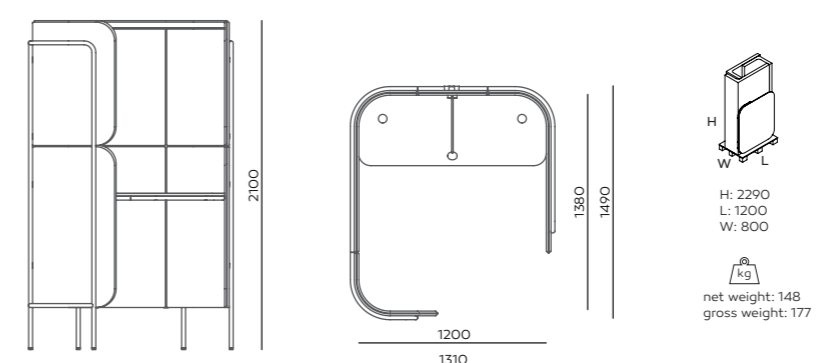

LP SNAKE POD H1

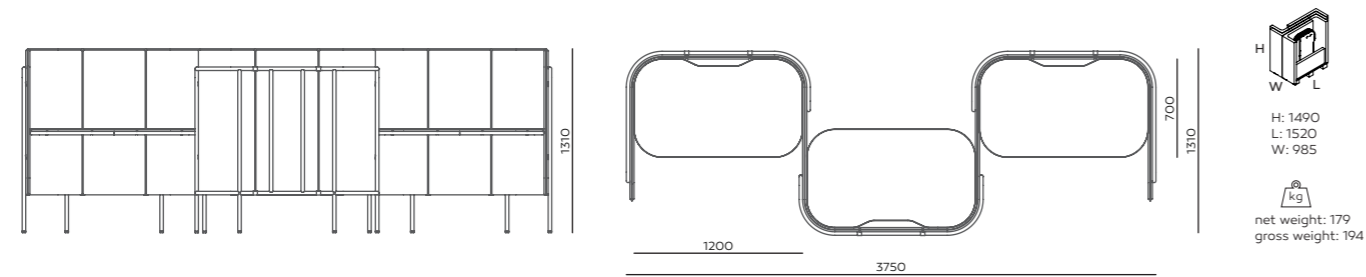

LP SOFA POD S H1

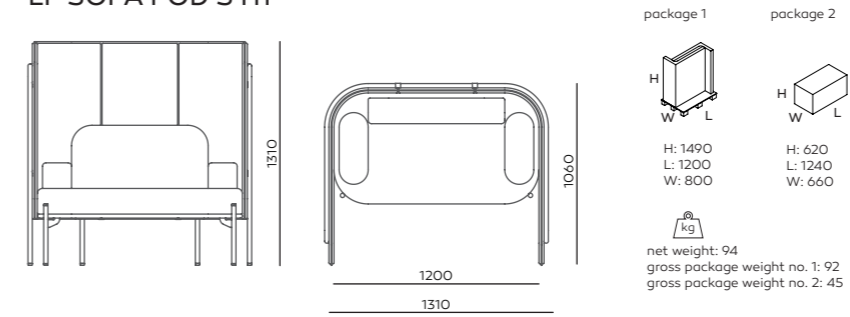

LP CHAT POD 1 H1

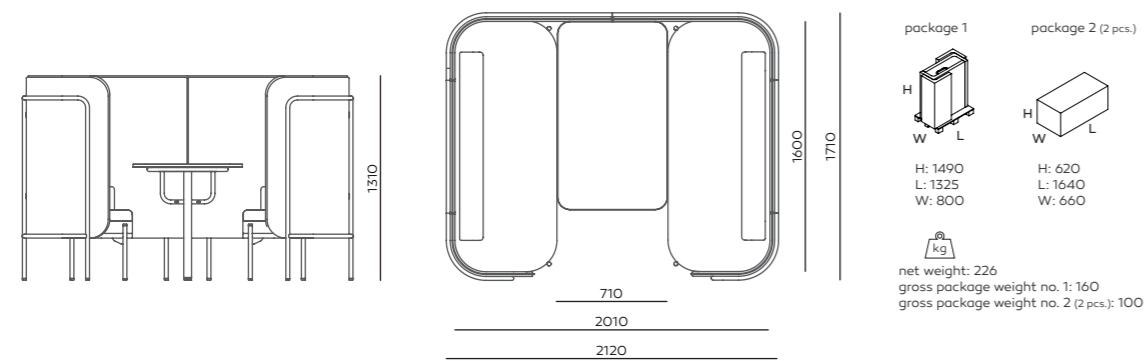

LP SOFA POD M H1

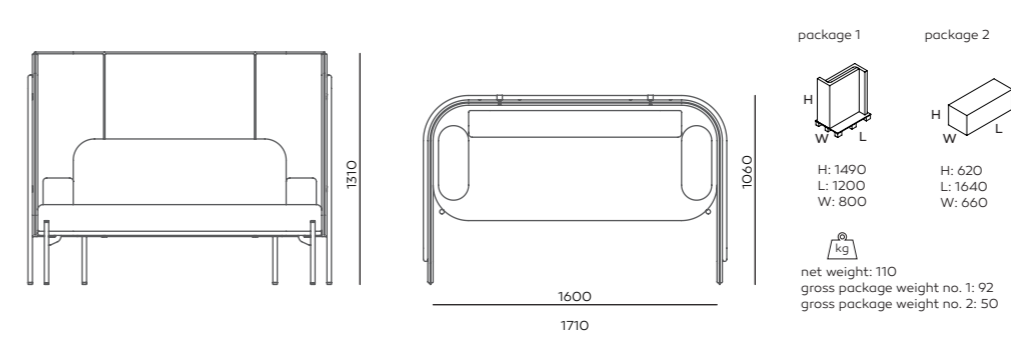

LP CHAT POD 2 H2

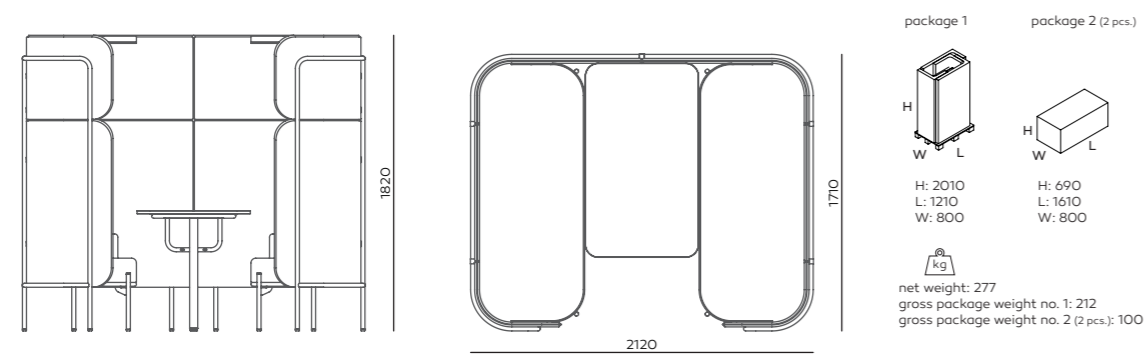

LP RECHARGE POD H2

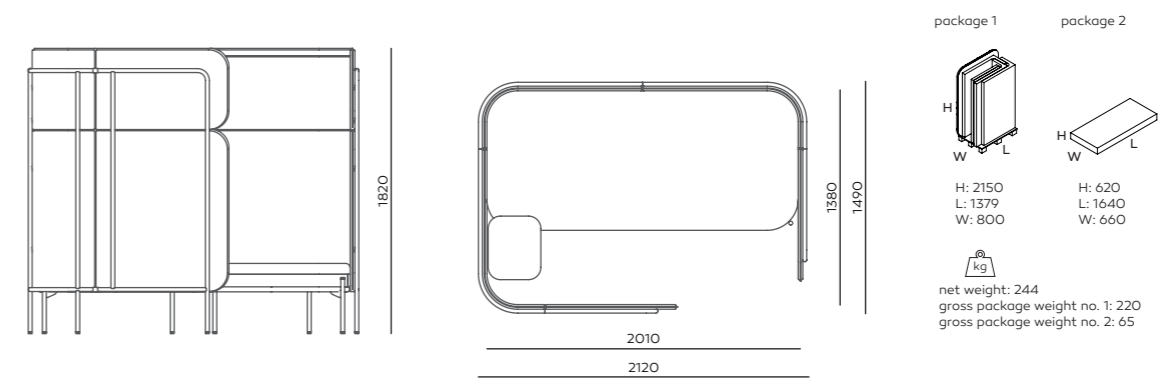

LP BRAINSTORM POD H3

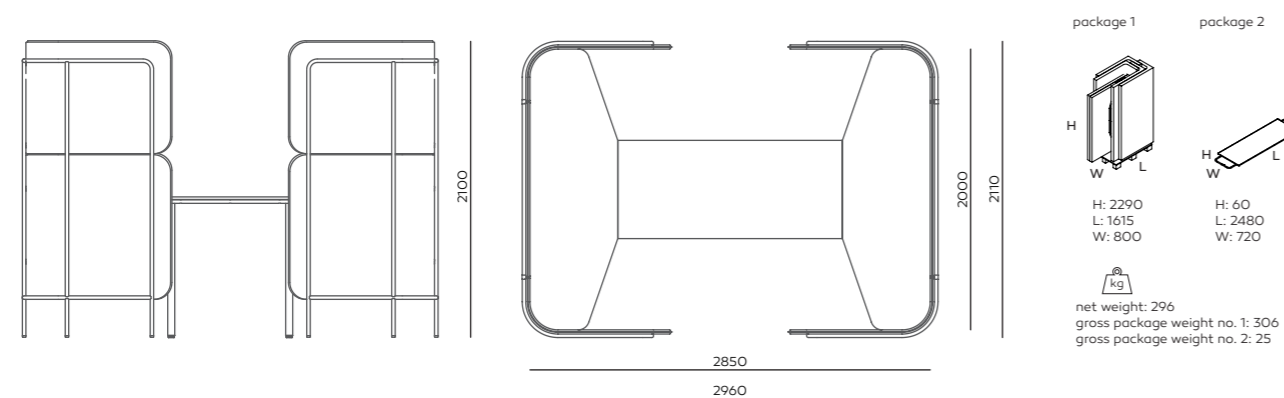

sofas free

LP SFF O

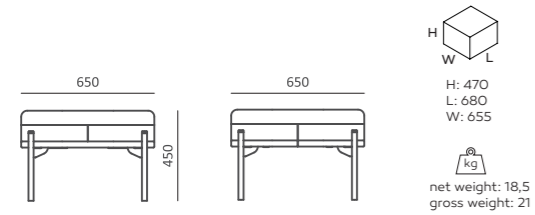

LP SFF 112

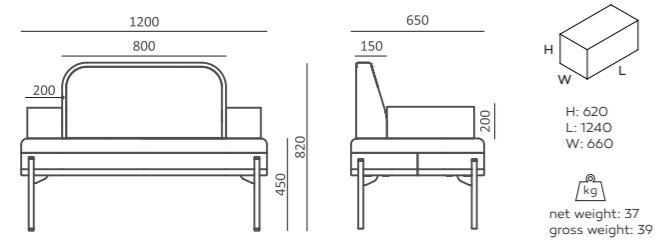

LP SFF 110 + TB410M

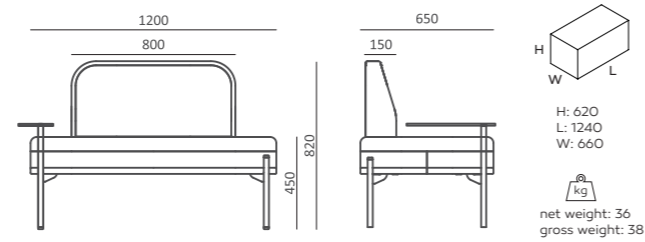

LP SFF 222

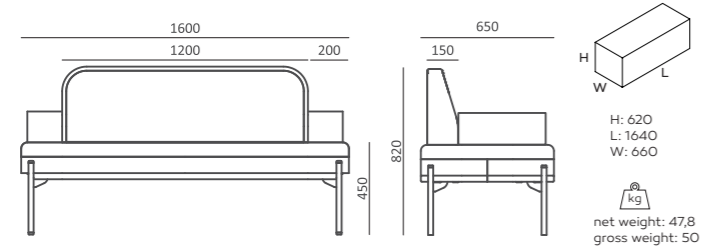

LP SFF 220 + TB410M

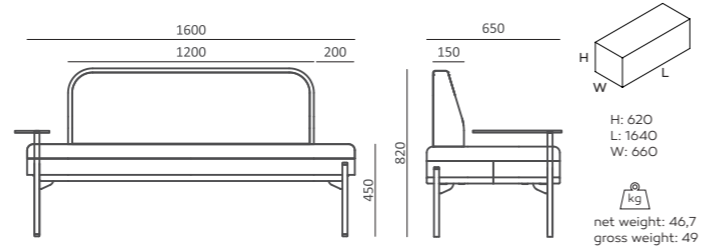

LP SFF 332

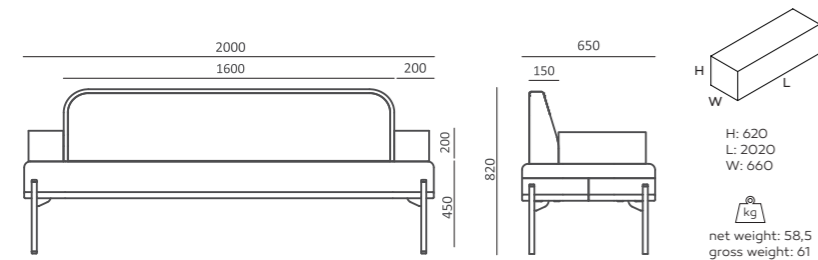

LP SFF 330 + TB410M

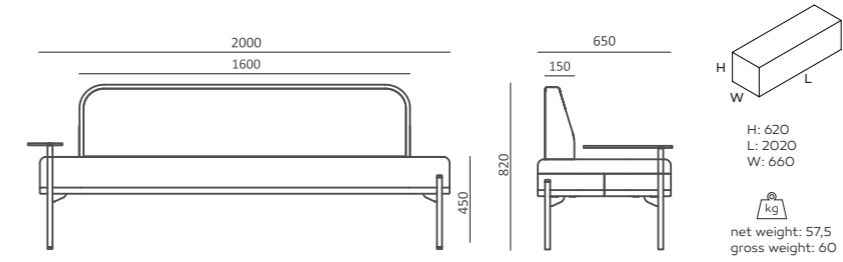

tabletops- sofa connectors

LP LTB 45

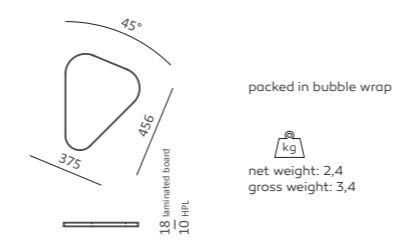

LP LTB 60

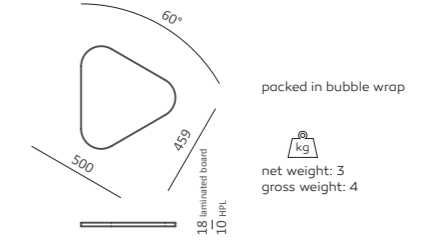

LP LTB 90

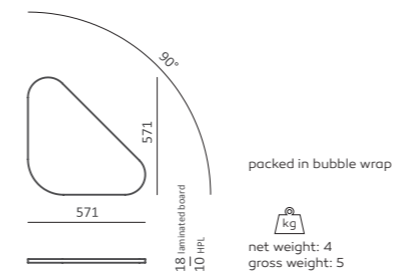

LP LTB 180

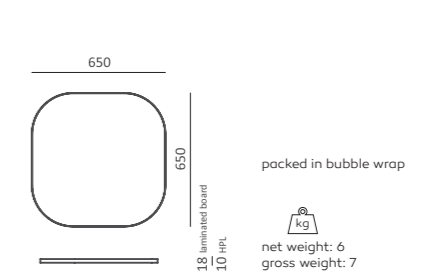

free-standing table

LP TB F650

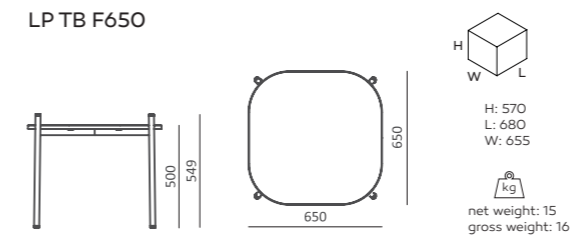



www.bejot.eu

Bejot Sp. z o.o. ul. Wybickiego 2A Manieczki 63-112 Brodnica n. Poznań
tel. +48 (61) 281 22 25 fax +48 (61) 281 22 54 e-mail: biuro@bejot.eu

10/2020