

alberi collection



bejot:



**Maciej
Karpiak**

en:

Maciej Karpiak has been running his own multidisciplinary design studio, Office for Design Maciej Karpiak, since 2004. At the Academy of Art in Szczecin, he runs the Bionics and Multidisciplinary Product Design studios. Repeatedly awarded in Polish and international design competitions.

pl:

Od 2004 r. prowadzi autorską multidyscyplinarną pracownię projektową Office for Design Maciej Karpiak. Na Akademii Sztuki w Szczecinie prowadzi pracownię Bioniki oraz Multidyscyplinarnego projektowania produktów. Wielokrotnie nagradzany w polskich i międzynarodowych konkursach projektowych.

de:

Seit 2004 betreibt er sein eigenes multidisziplinäres Designstudio, das Büro für Design Maciej Karpiak. An der Kunstakademie in Szczecin leitet er die Studios für Bionik und multidisziplinäres Produktdesign. Er wurde wiederholt bei polnischen und internationalen Designwettbewerben ausgezeichnet.

The Alberi panels are a perfect alternative to the standard acoustic panels. They will make your office peaceful and quiet maintaining a natural look.

be:biophilic
be:calm
be:harmonic
be:inspired
be:organic

bejot: of the world

be:inspired



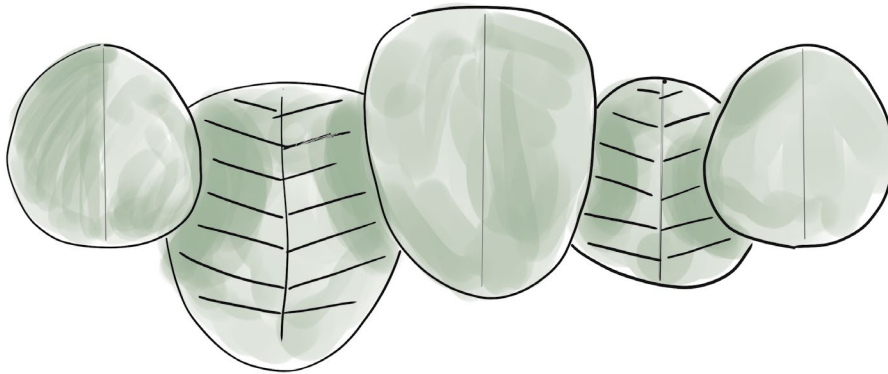
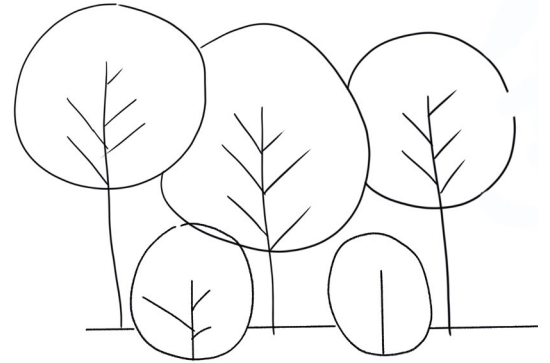

en:
Inspiration from nature

Alberi is a collection of acoustic panels with a wide range of configuration possibilities. The biophilic shape was inspired by trees, while the textures and colours relate to the seasons.

pl:
Inspiracje z natury

Alberi to kolekcja paneli akustycznych o szerokich możliwościach konfiguracji. Biofiliczny kształt został zainspirowany drzewami, a tekstury i kolory nawiązują do pór roku.

de:
Inspiration aus der Natur

Alberi ist eine Kollektion von Akustikpaneelen mit einer breiten Palette von Konfigurationsmöglichkeiten. Die biophile Form wurde von Bäumen inspiriert, während sich die Texturen und Farben auf die Jahreszeiten beziehen.



Alberi ALPSC 1580 W3
Upholstered with Blazer CUZ1K

Alberi ALPSC 1110 W1
Upholstered with Hush HS859

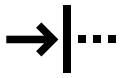

izolacja

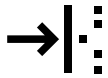

pochłanianie

alberi

design: Maciej Karpiak



ALSC 1110 W3

en:

Biophilia in the office

Alberi is an interesting alternative to standard acoustic panels. They not only improve the acoustics of the room, but also add variety to the interior with their biophilic shapes.

pl:

Biofilia w biurze

Alberi to ciekawa alternatywa dla standardowych paneli akustycznych. Nie tylko polepszają akustykę pomieszczenia, ale również urozmaicają wnętrze biofilicznymi kształtami.

de:

Biophilie im Büro

Alberi ist eine interessante Alternative zu herkömmlichen Akustikplatten. Sie verbessern nicht nur die Akustik des Raums, sondern bringen mit ihren biophilen Formen auch Abwechslung in den Innenraum.



Alberi ALSC 1580 W3

Upholstered with Blazer CUZ4K
Base: powder coated RAL 6021M

Alberi ALSC 1580 W1

Upholstered with Blazer CUZ3R
Base: powder coated RAL 6021M

Nubi NB P12

Upholstered with Remix RX123
Base: Oak O1



Alberi ALPSC 1580 W3
Upholstered with Hush HS860

Alberi ALPSC 1110 W1
Upholstered with Hush HS860

Nubi NB P18
Upholstered with Remix RX123
Base: Oak O1

Nubi NB SC12/18
Upholstered with Fenno FN005
Base: Oak O1



Alberi ALPSC 1580 W1
Upholstered with Blazer CUZ 53

Alberi ALPSC 1580 W3
Upholstered with Hush HS803

Alberi ALPSC 1110 W1
Upholstered with Blazer CUZ 53

Alberi ALPSC 1110 W3
Upholstered with Hush HS803

alberi:wall



en:

Biophilia on the wall

Alberi:wall are acoustic panels designed to be mounted on walls. Mounting rails available in 2 depths allow you to create any arrangement on the wall with a three-dimensional effect. The wall panels are available in two sizes and two embossing patterns.

pl:

Biofilia na ścianie

Alberi:wall to panele akustyczne przeznaczone do montażu na ścianach. Szyny montażowe dostępne w 2 głębokościach pozwalają na stworzenie dowolnej aranżacji na ścianie z trójwymiarowym efektem. Panele ściennie dostępne są w dwóch wymiarach i dwóch wzorach wytłoczeń.

de:

Biophilie an der Wand

Alberi:wall sind Akustikpaneele, die für die Montage an der Wand bestimmt sind. Die in 2 Tiefen erhältlichen Montageschienen ermöglichen eine beliebige Anordnung an der Wand mit einem dreidimensionalen Effekt. Die Wandpaneele sind in zwei Größen und zwei Prägemustern erhältlich.



Alberi ALSC 1580 W1

Upholstered with Blazer CUZ 2Q
Base: powder coated RAL 1019S

Alberi ALSC 1110 W1

Upholstered with Blazer CUZ86
Base: powder coated RAL 1019S

Alberi ALSC 1110 W3

Upholstered with Blazer CUZ 2Q
Base: powder coated RAL 1019S

Ox:co OX 215

Upholstered with Blazer CUZ 2Q
Base: powder coated RAL 1019S

Ox:co OX W 790

Upholstered with Blazer CUZ 2Q
Base: powder coated RAL 1019S and Oak O1

Table TB 29R L

Laminated tabletop U999
Base: powder coated RAL 9005 S

alberi:free



ALSC 1110 W1

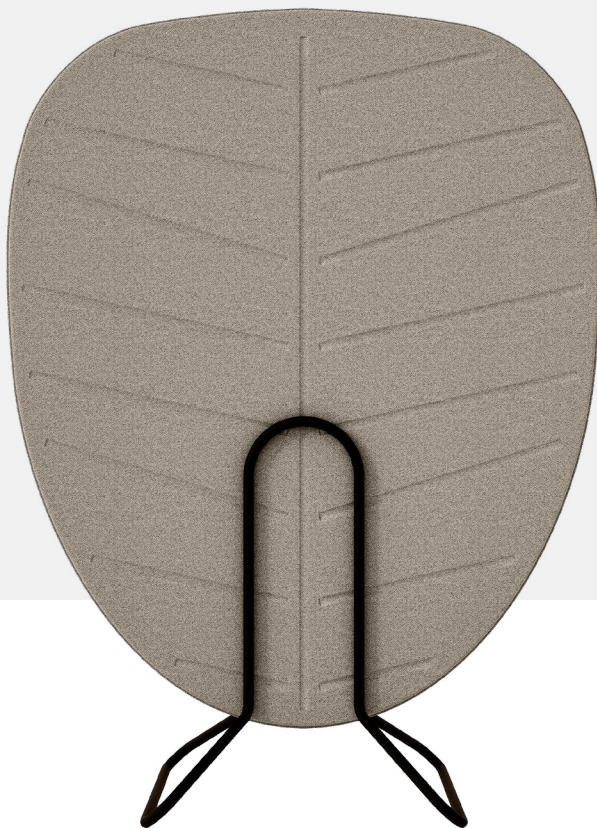

ALSC 1580 W3



en: easy stacking up to 5 screens
pl: łatwe sztaplowanie do 5 sztuk
de: Einfaches Stapeln von bis zu 5 Teilen

ALPSC 1580

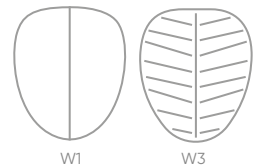

W1

W3

ALPSC 1110

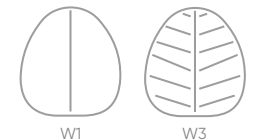

W1

W3

en:
be:free

Alberi:free is a free-standing, mobile noise barriers. A wide range of RAL colours allows interesting combinations of frame and fabric shades.

pl:
be:free

Alberi:free to wolnostojące, mobilne ekrany akustyczne. Szeroka paleta kolorów RAL pozwala na ciekawe łączenie odcieni stelaża i tkaniny.

de:
be:free

Alberi:free sind freistehende, mobile Lärmschutzwände. Eine breite Palette von RAL-Farben ermöglicht interessante Kombinationen von Gestell- und Stofftönen.

be:inspired

en:

The biophilic design of the Alberi collection is evident not only in the shapes of the panels. The carefully selected colours evoke the seasons and create positive emotions.

pl:

Biofiliczny design kolekcji Alberi widoczny jest nie tylko w kształtach paneli. Starannie dobrane kolory przywołują na myśl pory roku i pozytywnie wpływają na emocje.

de:

Das biophile Design der Alberi-Kollektion zeigt sich nicht nur in den Formen der Platten. Die sorgfältig ausgewählten Farben erinnern an die Jahreszeiten und rufen die richtigen Emotionen hervor.

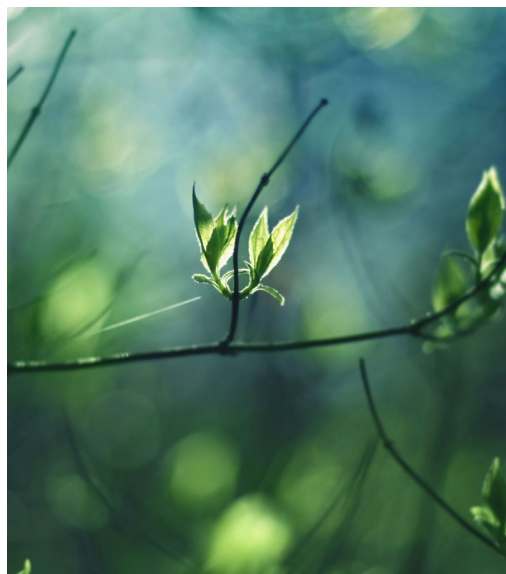

:spring



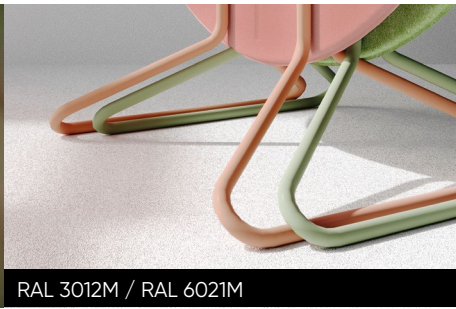
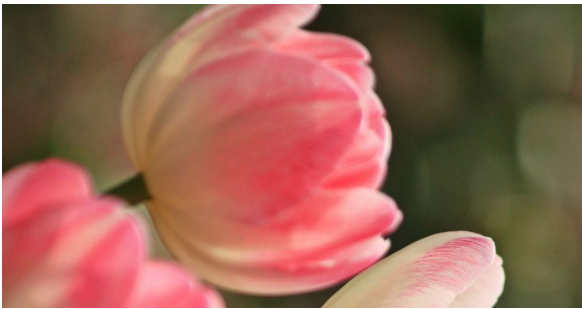

RAL 3012M / RAL 6021M

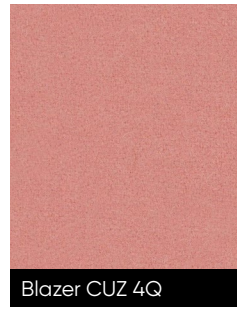

Blazer CUZ 4Q



Hush HS 859



Blazer CUZ 4K

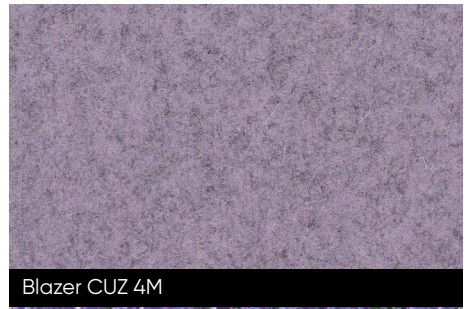

Blazer CUZ 4M

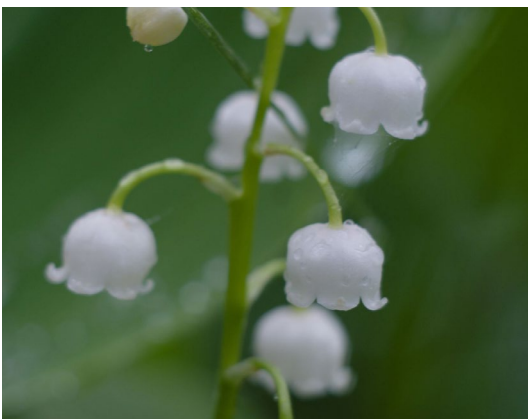

Blazer CUZ 3R

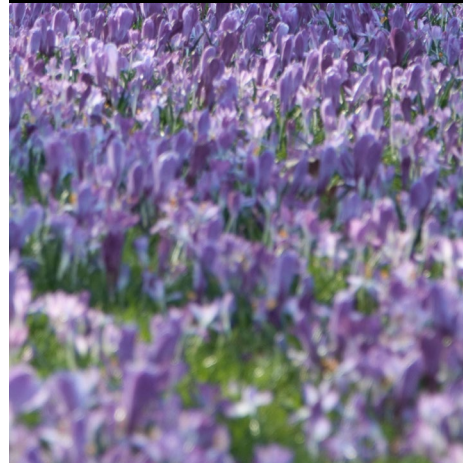

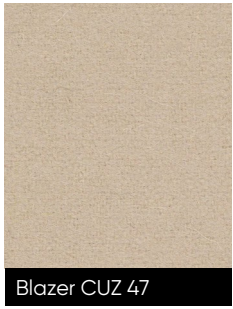
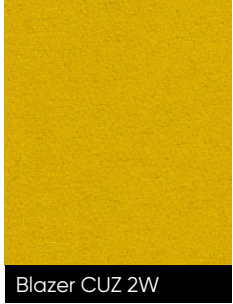

:summer





Hush HS 860



Hush HS 268



RAL 6021M / RAL 6005M

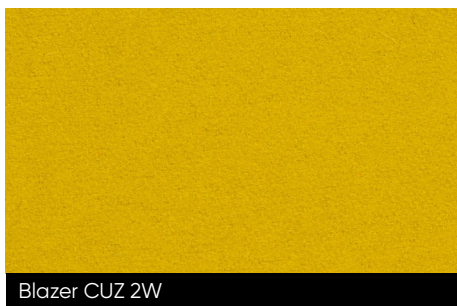

Blazer CUZ 2W

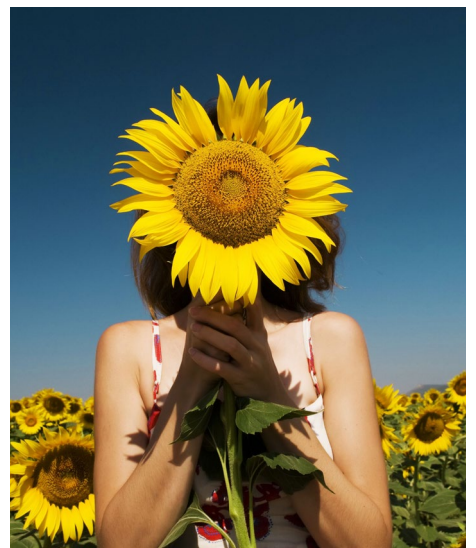

:autumn

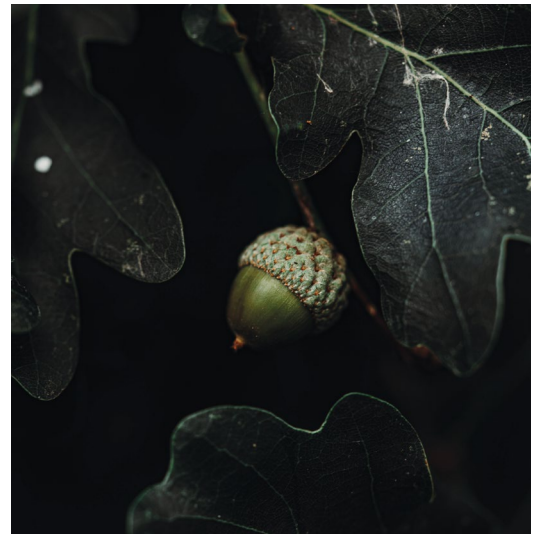
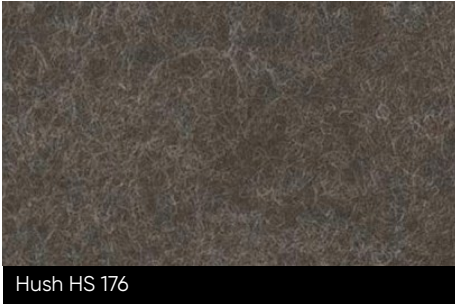



RAL 3005 M / RAL 3016 M

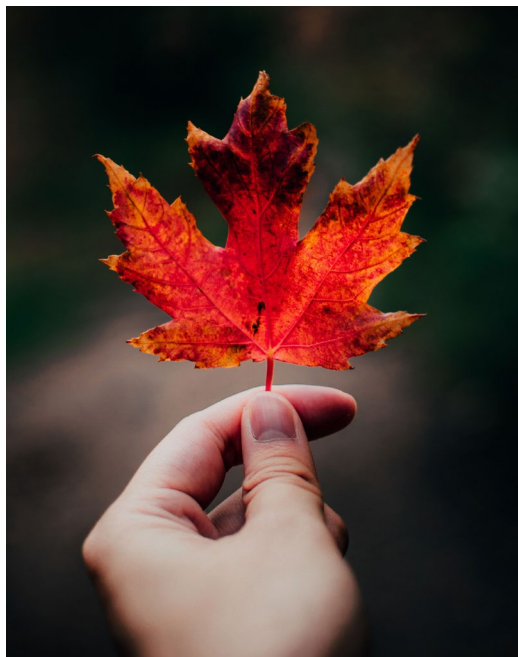

Hush HS 358

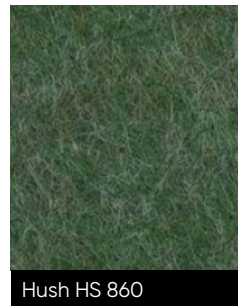

Hush HS 860





RAL 5014M / RAL 3016M



Blazer CUZ 30

:winter



Blazer CUZ 2Q

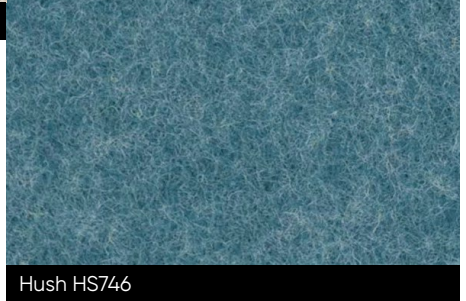

Hush HS746



Blazer CUZ 90

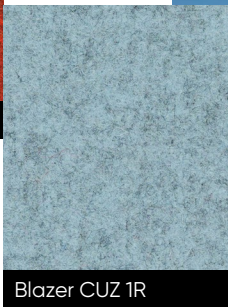

Blazer CUZ 1R



alberi:free



ALSC 1110 W1



ALSC 1110 W3

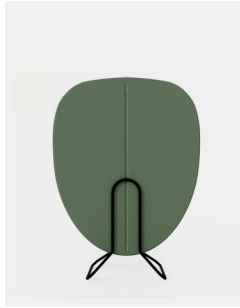

ALSC 1580 W1

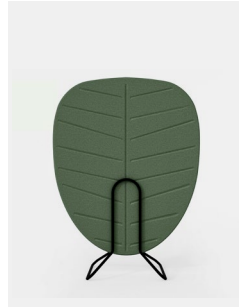

ALSC 1580 W3

en:

Base

Powder coated (colors according to the Bejot sampler).

pl:

Baza

Malowana proszkowo (kolorystyka wg wzornika Bejot).

de:

Basis

Pulverbeschichtet (Farbgebung nach Bejot-Musterkatalog).



RAL 9003 - S

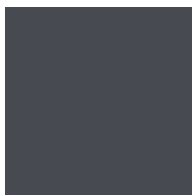

RAL 7024 - S

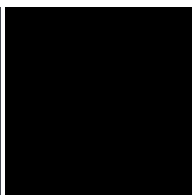

RAL 9005 - S



More colours
Więcej kolorów
Mehr Farben



en: Stackable up to 5 pieces

pl: Możliwość sztaplowania do 5 szt.

de: Stapelbar bis zu 5 Stk.

Technical data

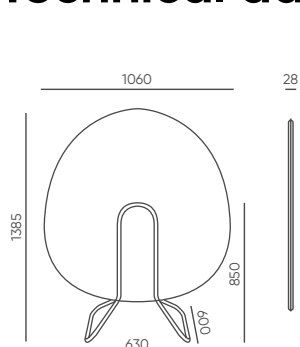

ALSC 1110 W1/W3

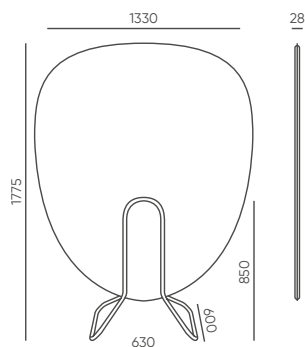

ALSC 1580 W1/W3

alberi:wall

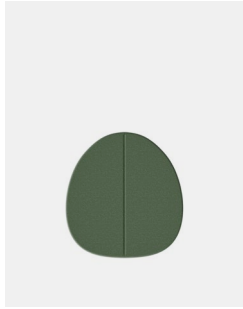

ALPSC 1110 W1

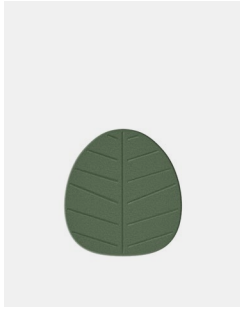

ALPSC 1110 W3



ALPSC 1580 W1

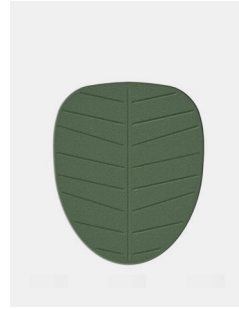

ALPSC 1580 W3

en: Mounting method

The pendants allow the panels to be mounted in four heights and the rails in two depths with a distance of 20 and 50 mm from the wall.

pl: Sposób montażu

Zawieszki pozwalają na montaż paneli na czterech wysokościach, a szyny w dwóch głębokościach z dystansem 20 i 50 mm od ściany.

de: Montageart

Die Pendelleuchten ermöglichen die Montage der Paneele in vier Höhen und der Schienen in zwei Tiefen mit einem Abstand von 20 und 50 mm zur Wand.

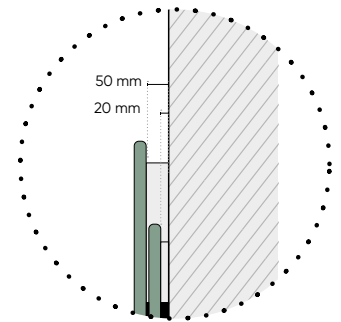
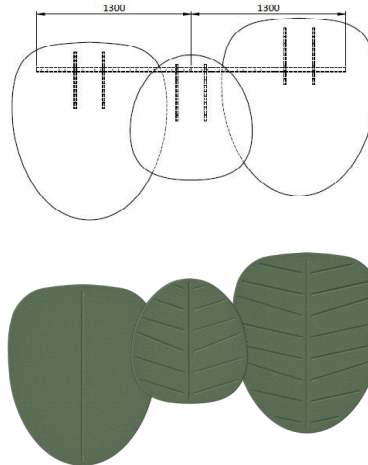
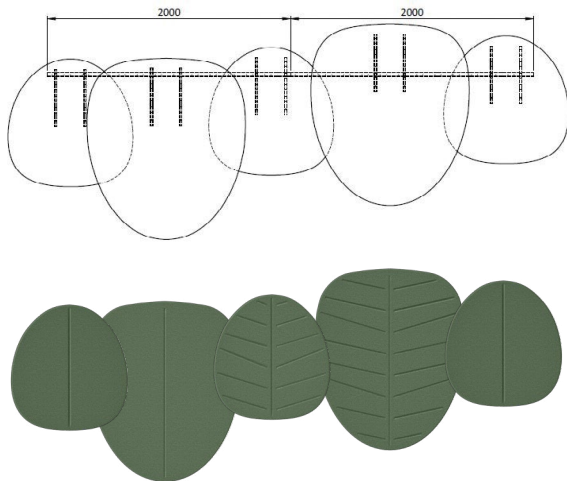

Technical data

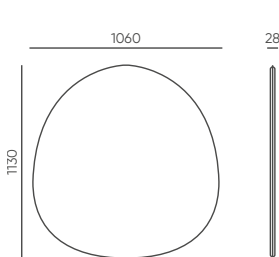

ALPSC 1110 W1/W3

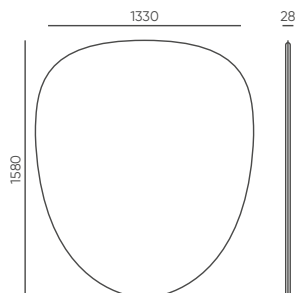

ALPSC 1580 W1/W3

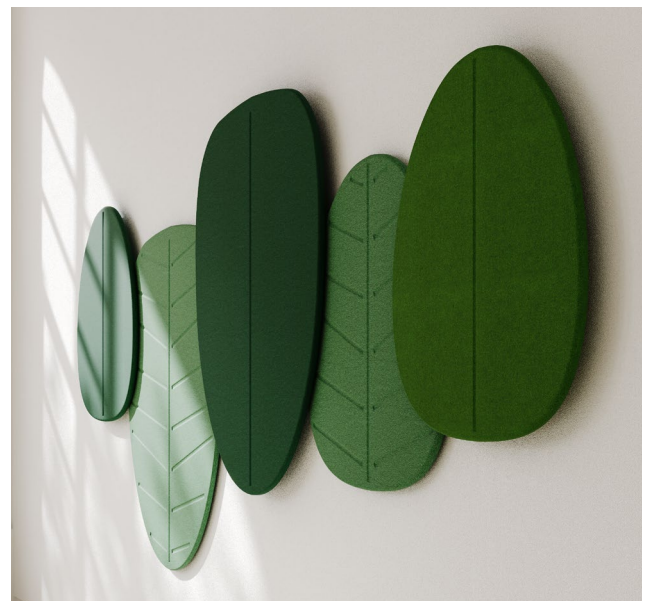

alberi:free



insulation

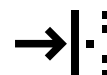

absorption

ACOUSTIC PARAMETERS

Alberi Free

Sound absorption coefficient α_s acc. to PN-EN ISO 354:2005.
 Współczynnik pochłaniania dźwięku α_s wg PN-EN ISO 354:2005.
 Schallabsorptionskoeffizient α_s gemäß EN ISO 354:2005.

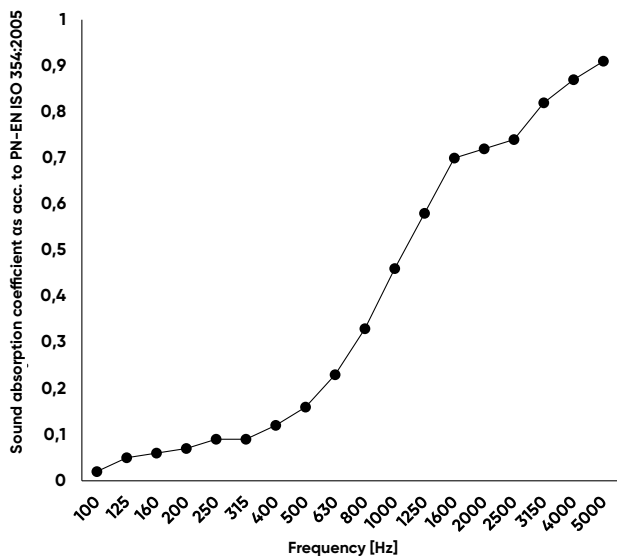

Alberi Free

Equivalent sound absorption area of a single object A_{obj} acc. to PN-EN ISO 354:2005*.
 Równoważne pole powierzchni dźwiękochłonnej pojedynczego obiektu A_{obj} wg PN-EN ISO 354:2005*.
 Äquivalente Schallabsorptionsfläche eines einzelnen Objekts A_{obj} nach PN-EN ISO 354:2005.

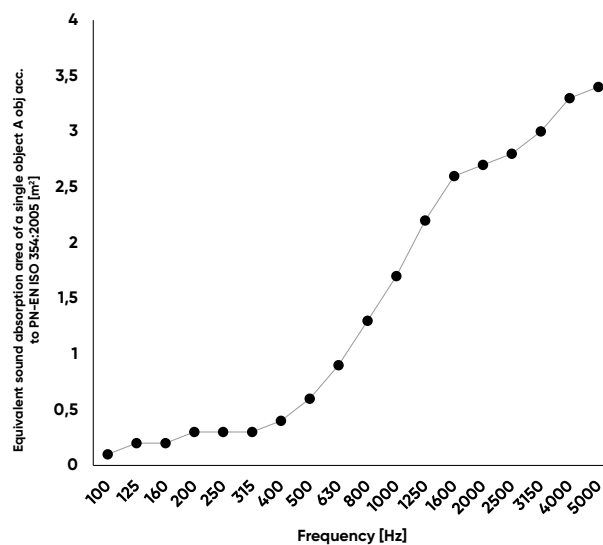

*results for Alberi AL SC1580.

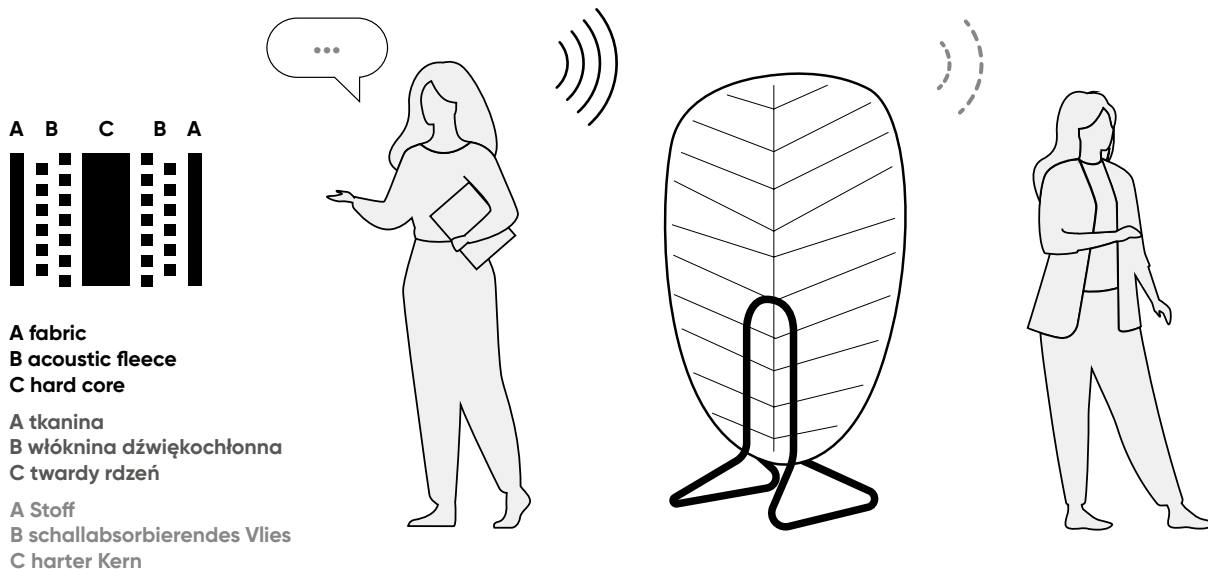

Tested parameter	Sound absorption coefficient α_s acc. to PN-EN ISO 354:2005	Sound absorption class acc. to PN-EN ISO 11654:1999
Alberi Free	0,3 (H)	D

ACOUSTIC PARAMETERS

Alberi Wall

Sound absorption coefficient α_s acc. to PN-EN ISO 354:2005*.

Współczynnik pochłaniania dźwięku α_s wg PN-EN ISO 354:2005*.

Schallabsorptionskoeffizient α_s gemäß EN ISO 354:2005*.

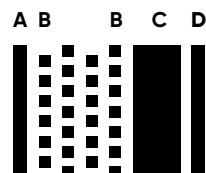
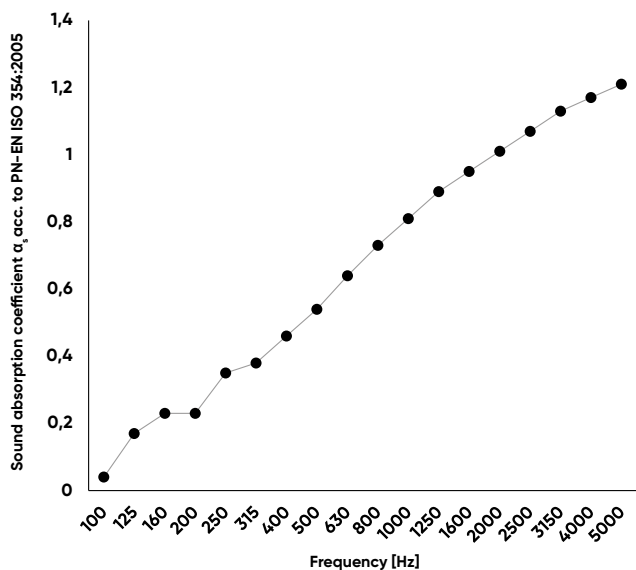

- A fabric
- B acoustic fleece
- C hard core
- D technical nonwoven fabric

- A tkanina
- B włóknina dźwiękochłonna
- C twardy rdzeń
- D tkanina techniczna

- A Stoff
- B schallabsorbierendes Vlies
- C harter Kern
- D technischer Vliesstoff

*average result for one object based on a compositional test.

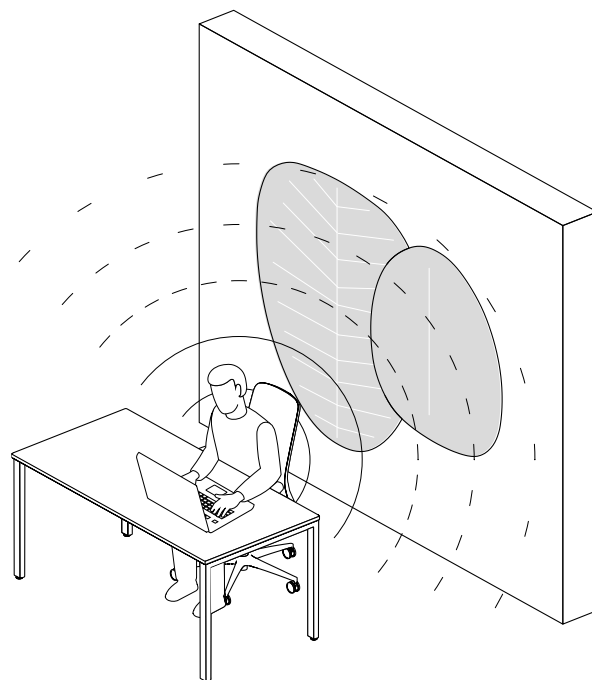
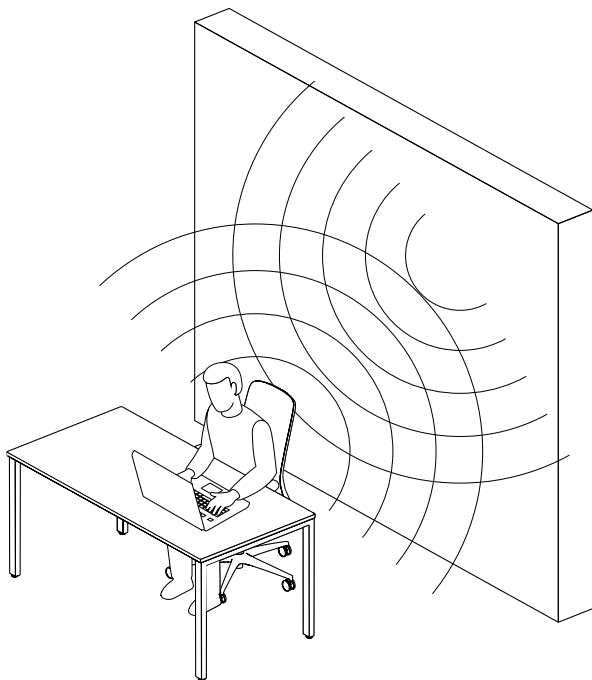

Tested parameter	Sound absorption coefficient α_s acc. to PN-EN ISO 354:2005	Sound absorption class acc. to PN-EN ISO 11654:1999
Alberi Wall	0,5 (MH)	D

wellbe:ing

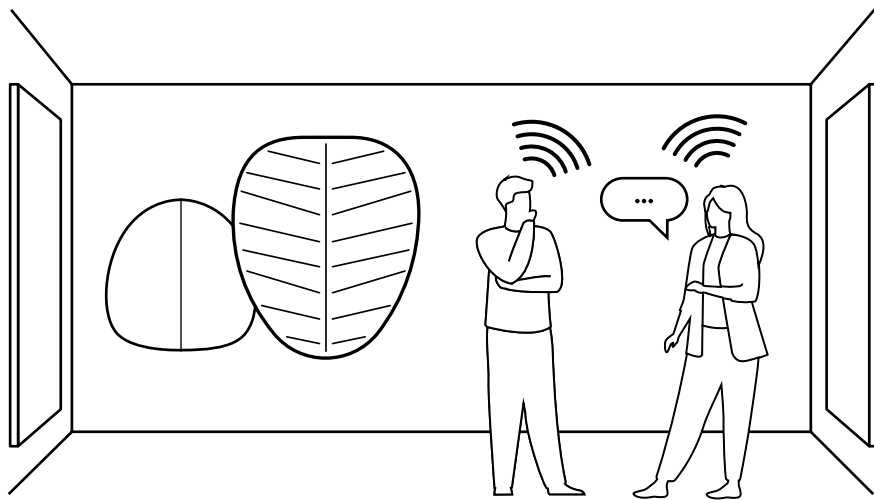

en:

Acoustic panels

Using acoustic wall panels to absorb excess reflections of acoustic waves results in reduced noise and increased speech intelligibility. This improves the comfort of work and ensures that meetings and conversations do not disturb other employees.

pl:

Panele akustyczne

Zastosowanie paneli akustycznych ściennych pochłania nadmiar odbić fal akustycznych, prowadząc do redukcji hałasu i zwiększenia zrozumiałości mowy. Dzięki temu poprawia się komfort pracy, a spotkania i rozmowy nie przeszkadzają reszcie pracowników.

de:

Akustikplatten

Der Einsatz von Akustikwänden absorbiert überschüssige Schallwellenreflexionen, was zu einer Lärmreduzierung und einer besseren Sprachverständlichkeit führt. Dies verbessert den Komfort bei der Arbeit und bei Besprechungen und Gespräche stören den Rest der Belegschaft nicht.

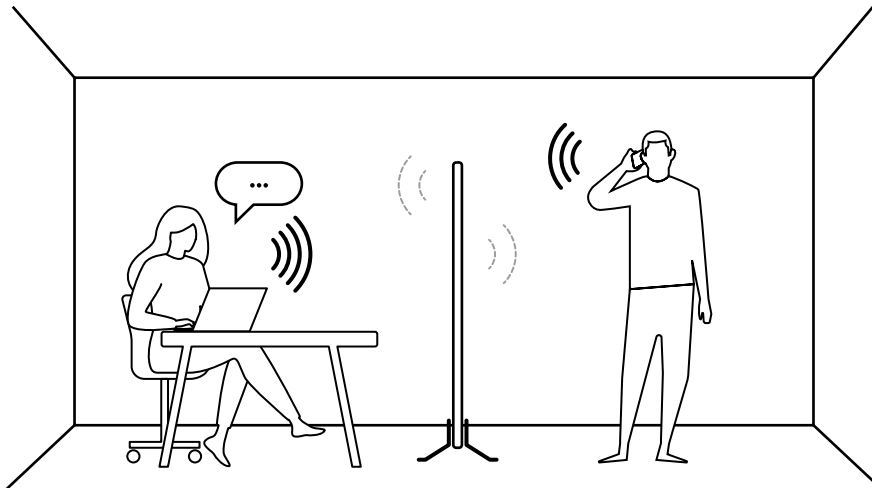

en:

Acoustic screens

Large conversation ranges and high noise levels in the office can be reduced by using freestanding acoustic screens. They limit sound penetration from one zone to another, so they are ideal for designating individual workstations or zones in open-plan offices.

pl:

Ekran akustyczny

Duży zasięg rozmów i wysoki poziom hałasu w biurze może zostać zredukowany dzięki zastosowaniu ekranów akustycznych wolnostojących. Ograniczają one przenikanie dźwięku z jednej strefy do drugiej, dzięki czemu świetnie się sprawdzają przy wydzieleniu poszczególnych stanowisk pracy lub stref w biurach typu open space.

de:

Schallschutzwände

The long range of conversations and high noise levels in the office can be reduced by using free-standing acoustic screens. They reduce the transmission of sound from one zone to another, making them ideal for separating individual workstations or zones in open-plan offices.

alberi collection – ecology and recycling

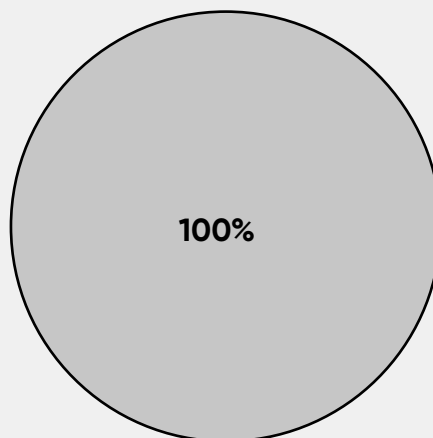
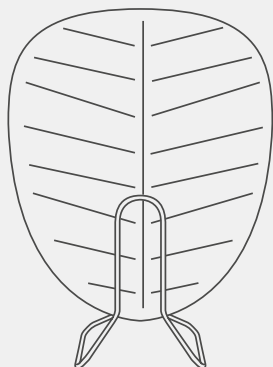

en:

We care about the environment

We use recyclable materials, e.g. in the sample Alberi ALSC 1580 presented above, we can reuse as much as 100% of the initial materials.

pl:

Dbamy o środowisko

Używamy materiałów podlegających recyklingowi, np. w powyższym przykładowym modelu Alberi ALSC 1580 możemy wykorzystać ponownie aż 100% mebla.

de:

Wir Schützen unsere Umwelt

Wir verwenden wiederverwertbare Materialien, wie z.B. bei den Alberi ALSC 1580 Sitzen oben, können wir bis zu 100% des Möbelstücks wiederverwenden.



wood / drewno / Holz

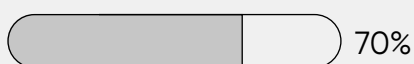

steel / stal / Stahl

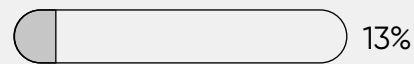

upholstery / tapicerka / Polster

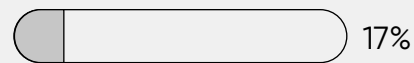

en:

Material composition

Percentage share, by weight, of a given raw material in the Alberi ALSC 1580.

pl:

Skład materiałowy

Procentowy udział masy danego surowca w ścianie Alberi ALSC 1580.

de:

Materialzusammensetzung

Gewichtsprozentsatz eines bestimmten Rohstoffs in der Alberi ALSC 1580.

Bejot sp. z o.o.

ul. Wybickiego 2A, Manieczki, 63-112 Brodnica n. Poznań, POLAND

tel.: +48 (61) 281 22 25, e-mail: marketing@bejot.eu

www.bejot.eu

edition 11/2024



www.bejot.eu