

hens

HS 230

: product card



The hens collection is characterised by Scandinavian design and functionality. It adheres to the principles of simplicity, usability and naturalness. The strong steel frame gives the chairs a loft character. Their raw form is balanced by the natural oak veneer and soft upholstery.

design:
Henrik Schultz

Product website
[website link](#)



bejot:

collection advantages

scandinavian design and functionality

The collection is a contemporary interpretation of the classic school chair. Designed with inspiration from Scandinavian design, it meets the objectives of simplicity, functionality and naturalness.

easy stacking

The chairs are perfectly stackable, and some models can be joined together with a dedicated rail. This makes them suitable for virtually anywhere - from offices to schools and public spaces.

practical armrests

The round cover (PUT) on the armrests is not only an aesthetic finish but also a functional solution that allows for the safe suspension of chairs on the table top. This facilitates keeping floors clean in conference rooms, canteens, and other spaces.

technical data

HS 230

Standard ●
Option ○

Base

Powder painted (colors according to the Bejot pattern book)	●
Chrome	○

Colours for the 1N/2N version

Natural oak veneer - clear varnish matt	ONB	●
Natural oak veneer - black matt varnish (RAL 9005M)	O9005	○
Natural oak veneer - gray matt varnish (RAL 7045M)	O7045	○
Natural oak veneer - maroon matt varnish (RAL 3005M)	O3005	○
Natural oak veneer - green matt varnish (RAL 6005M)	O6005	○
Natural oak veneer - blue matt varnish (RAL 5007M)	O5007	○

Armpads

Black polyurethane - PU type tube	PUT	●
Soft, black polyurethane - PU	PU	○

Additional equipment

Black masking panel that protects the chairs from scratches during stacking	CP	●
---	----	---

Glides

Glides for ceramic floors, concrete and carpets	SK	●
Felt glides for wooden floors and floor panels	SF	○

Description

Description	Code
Seat and backrest, natural oak veneer	1N
Upholstered seat / backrest, natural oak veneer	2N

dimensions

HS 230

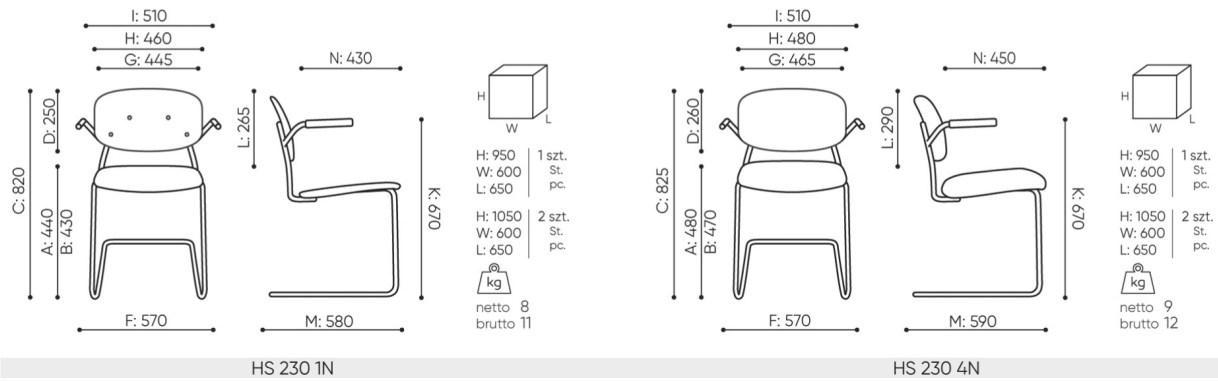

- A seat height: overall dimensions
- B seat height: measured according to the norm
PN EN 1335 - 1
- C chair height
- D backrest height
- E headrest height
- F dimensional width chair / base
- G seat width
- H backrest width
- I width between armrests
- K height from the floor to the armrest
- L backrest length
- M dimensional chair depth
- N seat depth / seat length

Dimensions are approximate and may vary depending on the selected product configuration. The requirements of the standard are always met.

materials available for collection

1st price group	Bond, Fenno, Keimo, Sawana
2nd price group	Alpa, Charles, Charles - Studio Design, Cura, Era - Studio Design, Pastel, Roccia
3rd price group	Ally, Ally SD, Alpa-Studio Design, Blazer, Cura SD, Easy SD, Oceanic, Rhythm, Silvertex , Silvertex - Studio Design, Synergy, Synergy - Studio Design
4th price group	Heritage, Oceanic-Studio Design, Remix - Studio Design
5th price group	Accessoire, Steelcut Trio 3
Leather	Leather
Natural oak veneer	Natural oak veneer
Metal	Metal - powder coated

bejot:hens

